

COOPER&HUNTER



Distributor information

[www.cooperandhunter.com](http://www.cooperandhunter.com)

# CHV5

ALL DC INVERTER MULTI VRF



**CHV5** DC Inverter Multi VRF System with its high-efficient inverter compressors has four exciting features which are different from those found on traditional inverter air conditioners: excellent energy-saving effect, more reliable and precise operation, smarter network control, providing users with best air conditioning experience.

## CONTENTS

05 CHV5

25 CHV5 Mini & Slim

33 CHV5 Heat Recovery

44 Indoor Units

65 Control System

83 Energy Recovery Ventilation(ERV)



# CHV5



## Key Features

### All DC Inverter Technology to Improve Compression Efficiency

All DC inverter compressor and high-performance high pressure chamber are adopted to reduce loss of overheat and improve compression efficiency from direct intake. Compared with low pressure chamber, the compression efficiency is improved. High-efficient permasyon motor is adopted to provide better performance than traditional DC inverter compressor.

### All DC Inverter Compressor

- All DC inverter compressor is used in this system. It can directly intake gas to reduce loss of overheat and improve efficiency.

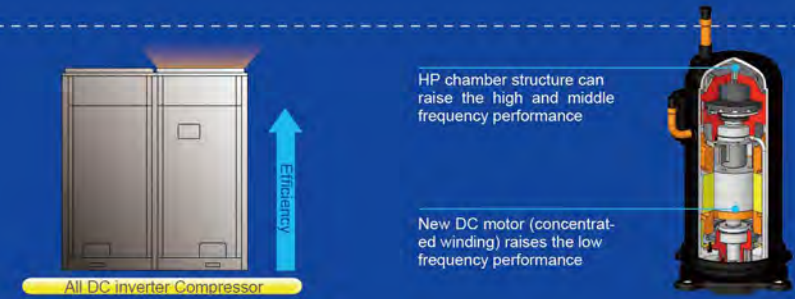

- High-efficient permasyon motor is adopted to provide better performance than traditional DC inverter compressor.



### Technology of Maximum Torque Control with Minimum Current

It can reduce energy loss caused by device winding so as to realize higher efficiency.

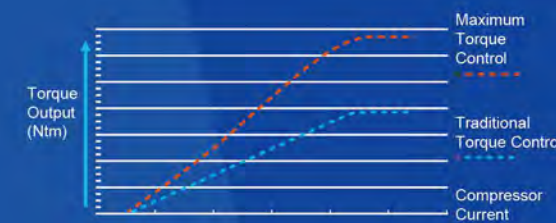

### Low-frequency Torque Control

It can directly control motor torque, through which fan motor can run at a low speed. Users will feel more comfortable while requirements of the system are also met.



- 180° Sine Wave DC Speed Varying Technology It can satisfy various places' demands for different temperature and is able to save a great deal of electricity and provide users with utmost comfort at the same time.

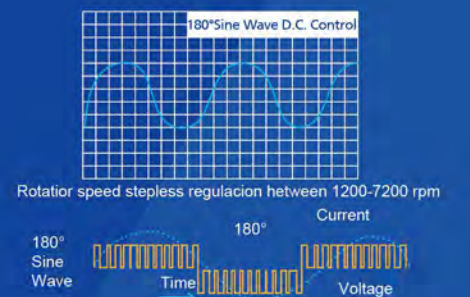
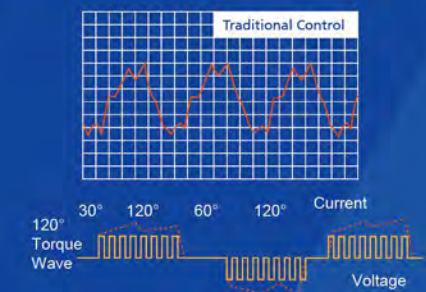

## Sensorless DC Inverter Fan Motor

- Stepless speed regulation ranges from **5Hz** to **65Hz**. Compared with traditional inverter motors, the operation is more energy-saving.

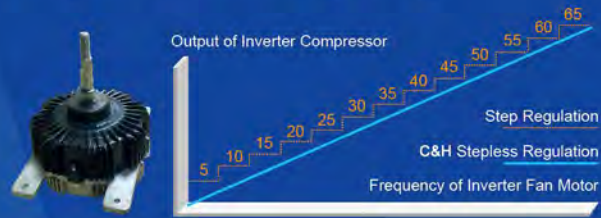

- Sensorless control technology guarantees lower noise, less vibration and steadier operation.

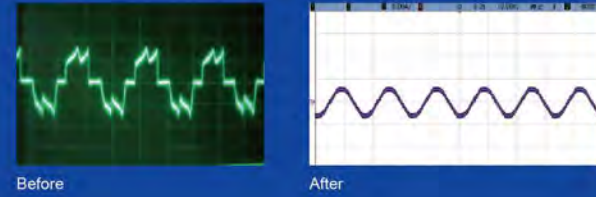

## Compact design

With compact design, the outdoor unit can be carried to the roof of building through elevator, with no need of crane. It is easier for delivery and installation.



## 88HP Max Capacity-The Largest Free Combination

Max capacity of single outdoor unit reaches **22HP** and max combination capacity is even up to **88HP**, in an industry leading level.

Max combination capacity is extended to 88HP



## Non-polar CAN Technology to Improve Communication Efficiency

- C&H is the first one to adopt non-polar CAN communication technology in the industry. CAN communication technology provides quicker system response speed, more convenient installation debugging and more reliable communication data.

Performance Index	Company A Multi-VRF Network	CHV5 DC Inverter CAN Network
Reliability	Software check	Hardware check, more reliable
	One unit's communication error may lead to a breakdown of the whole network	If one unit has errors, it will exit from the network without any influence to other units.
Communication Efficiency	Low utilization	High utilization
	Communication speed is about 10Kbps.	Communication speed is 20Kbps.
Compatibility	One main network, difficult to add new equipment	Multiple main networks, easy to add new equipment.
Communication Distance	1000m	1500m

Money is saved in system cost and piping



- The non-polar CAN communication technology is applied to support flexible wiring installation, greatly reducing construction difficulties.



## Wide Range of Voltage and Operation Condition

Working voltage range of CHV5 system has been improved to **320V~460V**, which surpasses the national standard of 342V~420V. For places with unsteady voltage, this system can still be running well.



Outdoor operation temperature range is improved to **-15°C~52°C in cooling** and **-25°C~24°C in heating**.



## Wider Applicable Location

CHV5 can realize a combination of 4 outdoor unit modules connecting with as many as **80** indoor units. It's especially applicable for business building or hotels.



## Refrigerant Storage and Distribution

The CHV5 system is designed without liquid receiver and the excess refrigerant is stored in the piping, which can minimize the refrigerant charging volume and enhance the control accuracy of refrigerant.

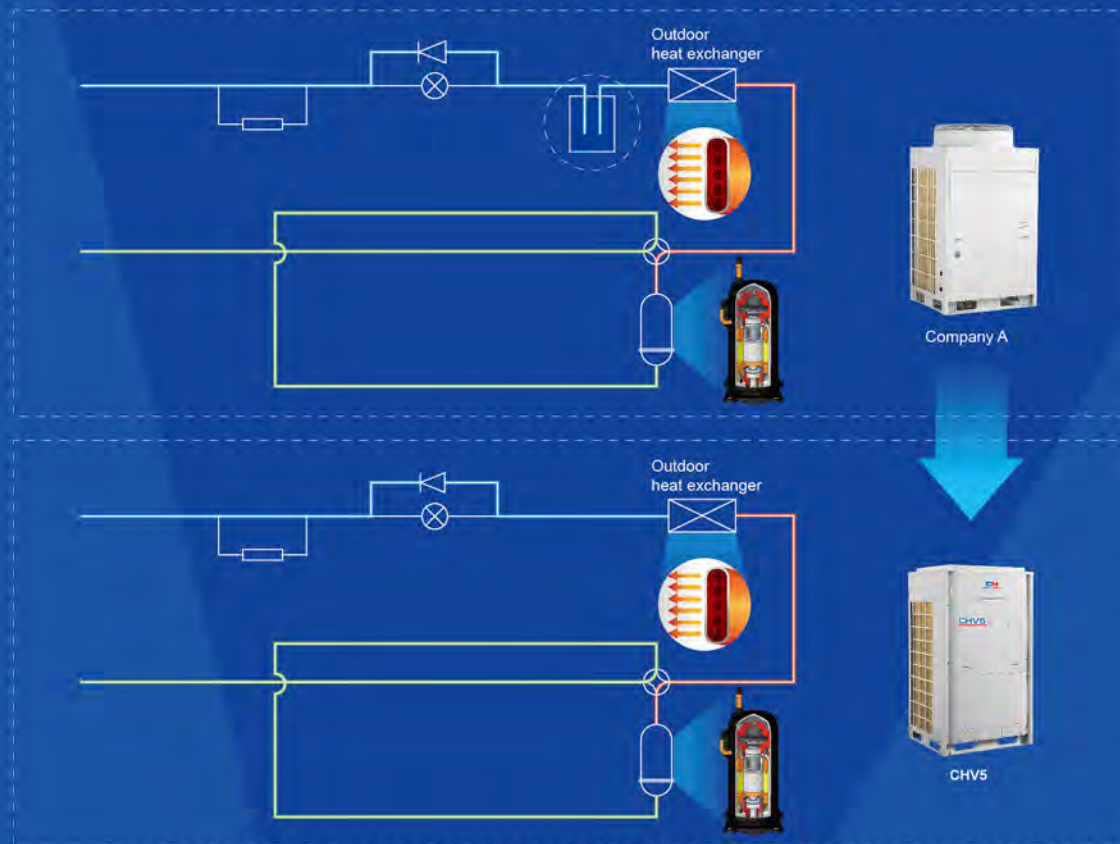

## High Efficiency and More Energy Saving

Thanks to the advanced all DC inverter technology, optimized system design and accurate intelligent control technology, IPLV of CHV5 All DC Inverter Multi VRF System is up to 6.8.

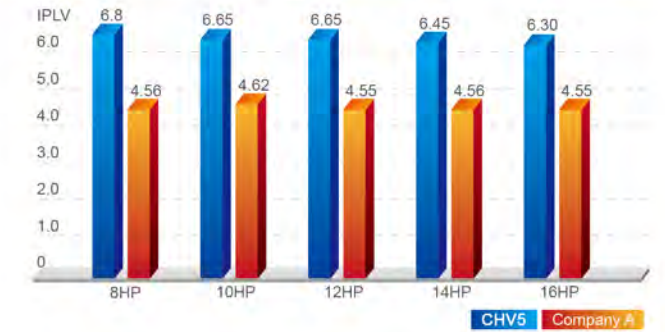

## New Generation of Energy-saving Operation Control Technology with Energy Saving Up to 20%

The CHV5 system has 2 modes for energy saving, which can be chosen to meet different electricity demands.

**Mode 1:**

In auto energy-saving mode, the system will self-adjust parameters according to the operation status, thus to lower the cost of electricity. Up to 15% of energy can be saved.

**Mode 2:**

In compulsory energy-saving mode, the system will limit power output forcibly. Up to 20% of energy can be saved.

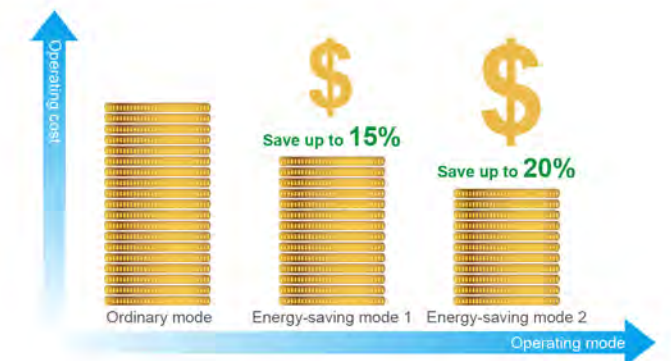

## Comfortable Heating

Advanced intelligent defrosting mode is adopted. C&H advanced intelligent defrosting mode will choose the best defrosting way according to outdoor temperature and operation status to realize intelligent defrosting, effectively improving heating effect and performance. While in traditional defrosting mode, timing defrosting is adopted, which not only affects comfort but also reduces energy efficiency.

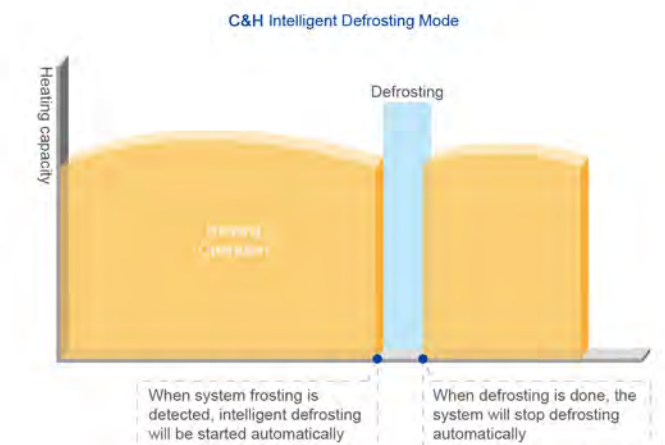

## Accurate Intelligent Allocation Technology of Capacity and Output of Optimal Portion to Ensure Highest Efficiency

- When total load demands more than 75% of a running system's capacity, one more unit will automatically start;
- When total load demands less than 40% of a running system's capacity, one unit will automatically shut down;
- Therefore, each unit shares 40%-75% of the total load.
- Experiments show that an air conditioner costs the least energy when it's operating within 40%-75% of its capacity.

	Company A	CH CHV
Allocation Method	10HP(full load) + 2HP(low load)	6HP(partial load) + 6HP(partial load)
Performance Compared	Unit costs more energy and may be soon damaged.	Unit costs less energy and can always be kept in good condition.

### Output of Optimal Portion to Ensure Highest Efficiency

The best heating or cooling performance can be realized in the most energy-saving way. DC inverter compressor and DC inverter fan will also be operating in this way to ensure high efficiency.



## Sub-cooling Control Technology to Ensure Optimal Cooling and Heating

- Heat exchange loop can control the first subcooling process of heat exchanger. Subcooling degree can reach 11 C.
- Subcooling loop can realize 9 C second subcooling to guarantee cooling and heating performance.

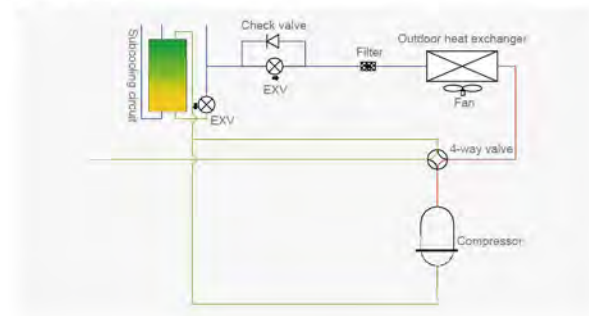
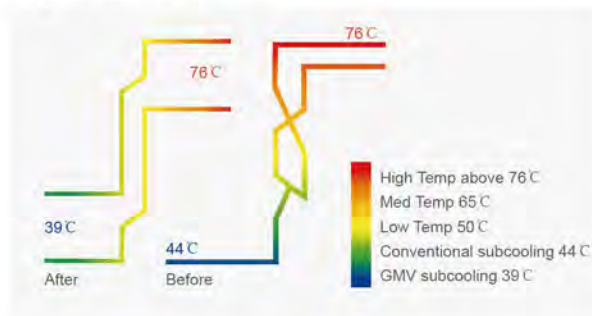

## Temperature Controlled by Wired Controller with Higher Efficiency and More Energy Saving

Through setting temperature lower limit in cooling or dry mode, and setting temperature upper limit in heating, 3D heating or heat supply mode, the system is able to operate in a smaller temperature range so as to achieve energy saving.

## Comfortable Design for A Better Life

The CHV5 system has a wide range of working conditions. Whether it's in a cool winter or a hot summer, normal operation is guaranteed with the least noise, making users feel more comfortable.

### Outdoor Unit Quiet Mode and Quiet Control

#### Quiet at night

The system can record the highest outdoor temperature. At night, the system will automatically turn to quiet mode. There are 9 quiet modes which can be set according to actual needs.

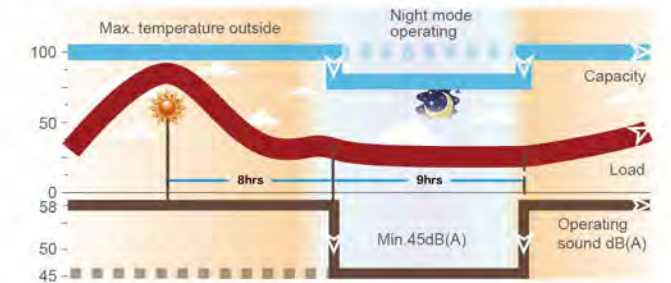

#### Quiet in compulsion

The system can also be set in this mode to ensure low noise as long as it is operating. Noise is as low as 45dB(A).



#### Quiet Control

##### 1. Optimized Bossing Design

After many times of CFD tests, a new fan bossing structure has been developed to reduce vibration of fan during running. Noise can be reduced by 3dB(A).

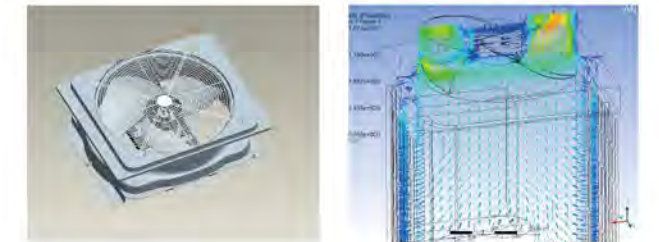

##### 2. Aerodynamics 3D Axial Fan

Compared with conventional fan, it can increase air volume by 12%, improving efficiency as well as lowering noise.



## Quiet Indoor Unit

The indoor unit of the CHV5 system also adopts DC inverter motors to realize stepless regulation. According to indoor temperature or people's needs, users can set this mode through wired controller. Noise is as low as 22dB(A).



## Fast Start-up in Heating

DC Compressor is first started to avoid too much electric current. Inverter compressor can operate in high frequency once starts up, so as to produce more heat.

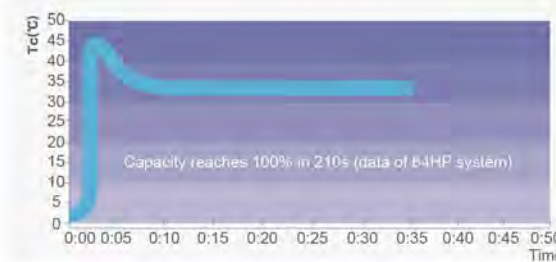

## 7 Speeds Indoor Fan

Indoor fan speed can be set in 7 levels by wired controller. They are auto, low speed, medium-low speed, medium speed, medium-high speed, high speed and turbo. When the wired controller is on, press "FAN" button to set indoor fan speed circularly as below:

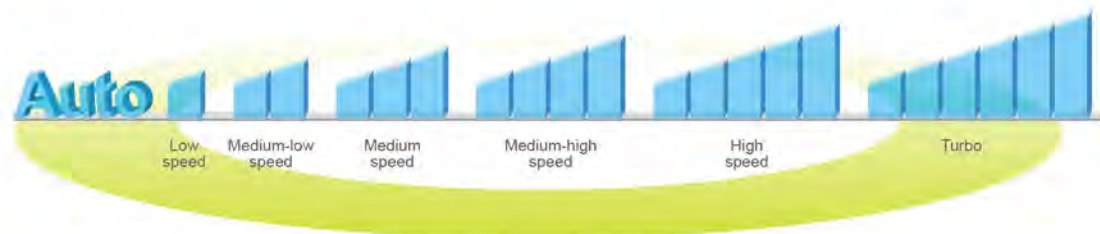

## Excellent Performance Ensured by Advanced Technology

Through 10 years of research and development, C&H CHV5 has been further upgraded to a high level from electrical components, mechanical parts, control technology to communication technology.

## Two-stage Oil Separation Control Technology (Patented)

First-stage oil separator adopts a filtration expansion valve with separation efficiency of 98%; Second-stage oil separator will separate the remained 2% refrigerant oil with separation efficiency of 95%. General oil separation efficiency reaches 99.9%.

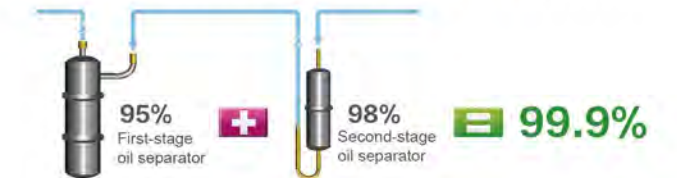

## Oil Return Control Technology

### New Oil Return Control

C&H new oil return control technology effectively controls system oil return and oil storage status of each compressor, which greatly improves the operation lifespan of compressor.

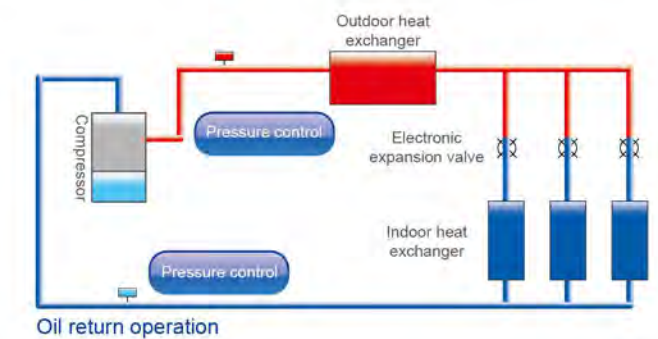
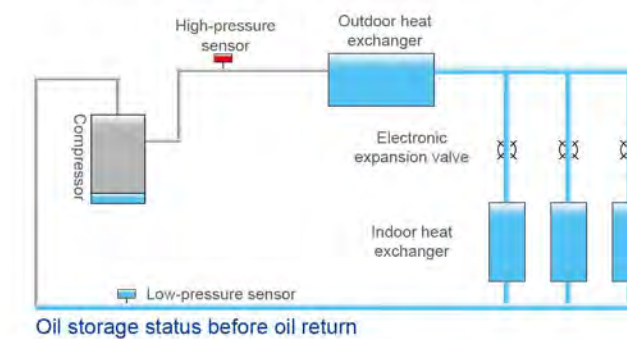

### Specialized Compressor Oil Storage Control

The system applies specialized compressor oil storage technology, which can control the lowest oil level for compressor operation.

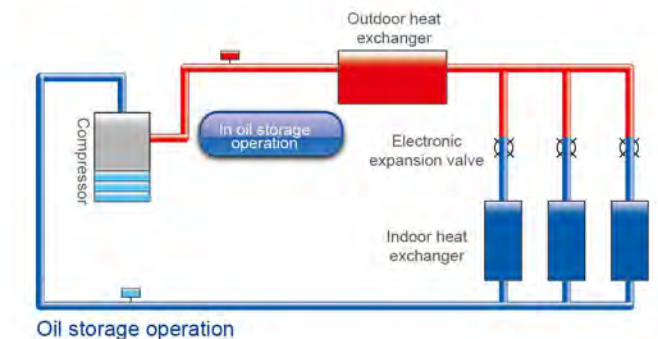

## Oil Balance Control Technology

### Oil Balance between Each Module

Based on the actual status of each module and compressor, the system can regulate compressor's operation and realize oil balance of each module.

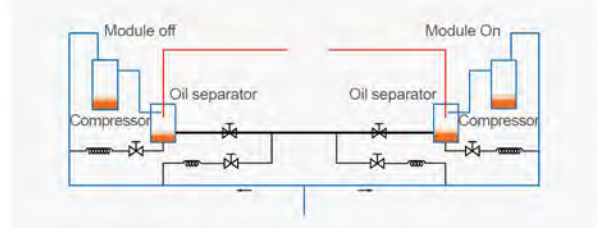

### Oil Balance between Each Compressor

Refrigerant is taken into the compressor by the suction pipe and then runs through the cooling system. It can control the oil level and minimum oil volume required by each compressor so as to realize oil balance between each compressor.

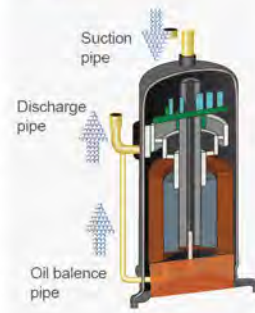

## Intelligent Detection Control

### Pressure Sensor Detection Control

Pressure sensor can precisely detect system high pressure and low pressure, and adjust output of fan and compressor, so as to make sure the system can work under the most energy-saving pressure condition.

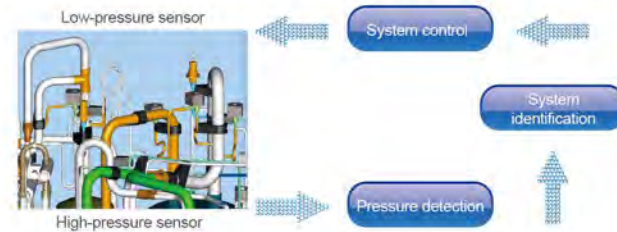

### Temperature Sensor Detection Control

Various temperature sensors are equipped to detect ambient temperature, indoor temperature and refrigerant's evaporating temperature, from which the operation status can be measured.

## Multi Electronic Expansion Valves Control

Outdoor electronic expansion valve not only has throttling effect, but also control refrigerant flow. The system adopts multi electronic expansion valves control with total 960 grades regulated by two electronic expansion valves, so as to regulate refrigerant flow precisely and ensures reliable operation of system.



## Smaller Impact to Power Grid

The start-up frequency of inverter compressor is gradually increased from 0Hz to the appointed operation frequency. The start-up current of compressor rotor is decreased by reducing load torque, hence impact to power grid during start-up is reduced and electromagnetic impact to compressor is reduced too.



## Modules Rotation Operating to Maximize Lifespan

### Modules 8h rotation operating

The operating priority sequence of the outdoor unit modules will be changed without restart when the system accumulatively operates for 8 hours, which can maximize the service life of the system.



## Highly Anticorrosive Golden Fins

The primary material of Golden Fin is Al-Mn(Aluminum-Manganese) anti-rust alloy, which is coated with the Golden Protection Layer(Components: Epoxy Resin & Modified Acrylic, Silicon free), the anti-corrosive performance in salt-spray testing is 200%~300% higher than normal Blue Fin\*.

Note: Salt-spray testing result is from C&H materials chemistry testing laboratory.

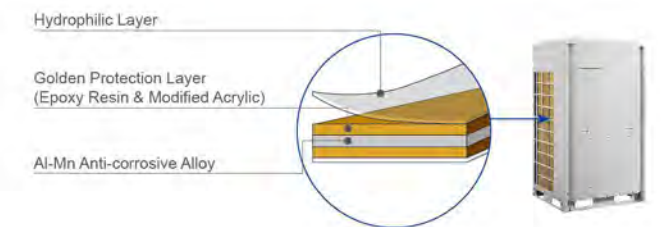

## Emergency Auto-Off Control

The outdoor unit can be linked with a fire alarm signal. In case of emergency, unit can automatically turn off to avoid risk or further loss.





## Electricity Shortage Identification

The outdoor unit can receive a power signal of electricity shortage. In some places like first-class hotels, if diesel generator is used temporarily for providing electricity, outdoor unit will send the electricity shortage signal to indoor unit. In this case, only VIP rooms can be provided with air conditioning service.

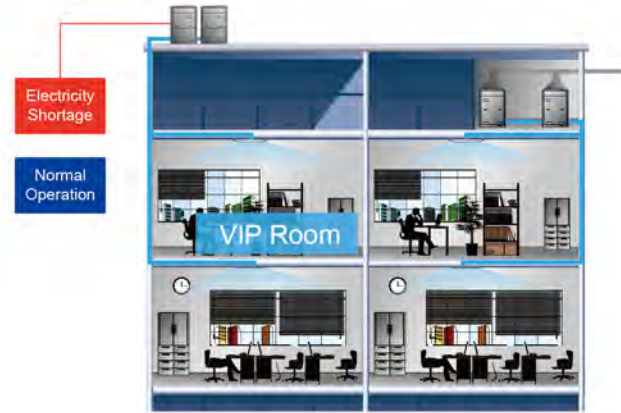

## Excellent Emergency Operation Function to Ensure Reliable Operation

### Emergency Function

The CHV 5 system can realize a combination of 4 outdoor unit modules. When error is occurred to one of the modules, the others will perform the emergency operation to sustain the air conditioning.



### Emergency Operation of Compressor

All the compressors in each single module are DC Inverter based, when one compressor has error, others will perform the emergency operation.



### Emergency Operation of Fan

Double-fan design fan ensures that one fan can still work even if the other one has error.



## Easy Installation for Various Kinds of Construction

### ODU High Static Pressure Design

System has 4 levels of static pressure that can be set. Up to 82Pa pressure can be set for an outdoor unit. This design is especially useful when an outdoor unit needs to be placed indoor.



### 1000m Pipe Design for Flexible Installation

CHV 5 system can be applied in different types of building construction. One of its advantages is the simple pipe design, which will simplify the installation and reduce installation cost.

- Max total pipe length reaches 1000m (with limitation)
- Actual pipe length between the outdoor unit and the farthest indoor unit: 165m
- Max height difference between indoor unit and outdoor unit: 90m

Note:  
a: Distance between the first branch and the farthest indoor unit.

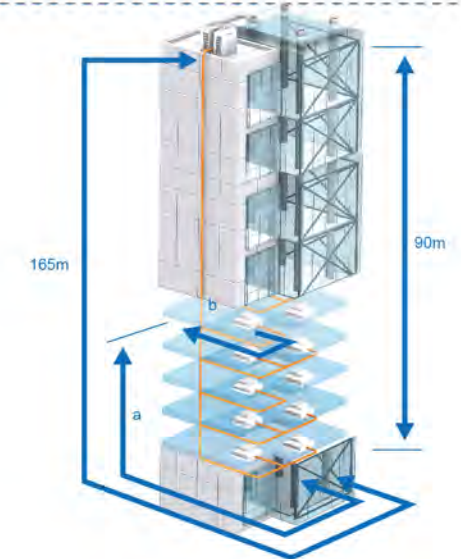

### Intelligent Debugging for Convenient Construction

CHV5 has five auto debugging features:

- Automatic allocation of IDU and ODU addresses
- Automatic detection of IDU and ODU quantity
- Automatic detection of errors
- Automatic start-up of debugging
- Real-time judgment of pipe errors

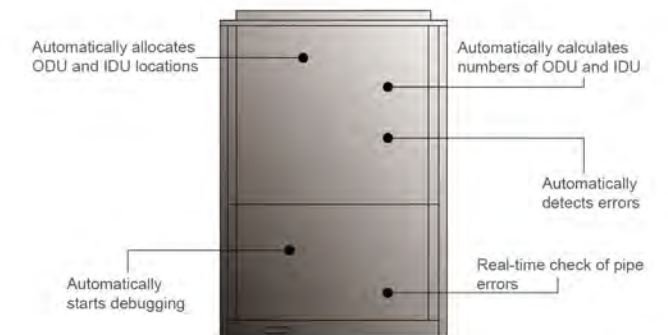

## Auto-refrigerant Recovery for Easy Maintenance

When auto refrigerant recovery function is set and cut-off valve of liquid pipe is closed during maintenance, the system will automatically operate compressor, EXV, solenoid valve and fan, etc. Taking advantage of compressor power, the refrigerant is recovered at the condensing side of outdoor unit to achieve environmental effect. Meanwhile, system low pressure is displayed simultaneously during refrigerant recovery.

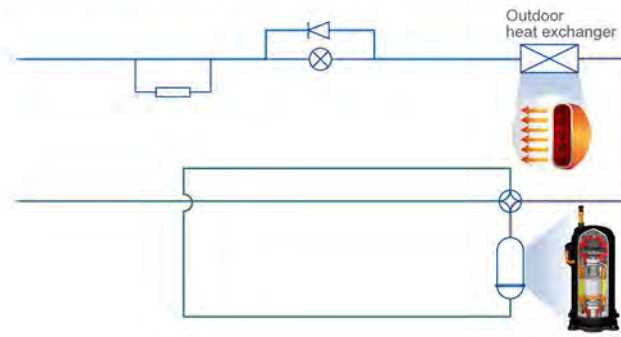

## Inspection Window for Convenient Checking

Inspection window is available for quick checking of system operation status. No need to open panel for checking, which will be more time-saving and easier for maintenance.

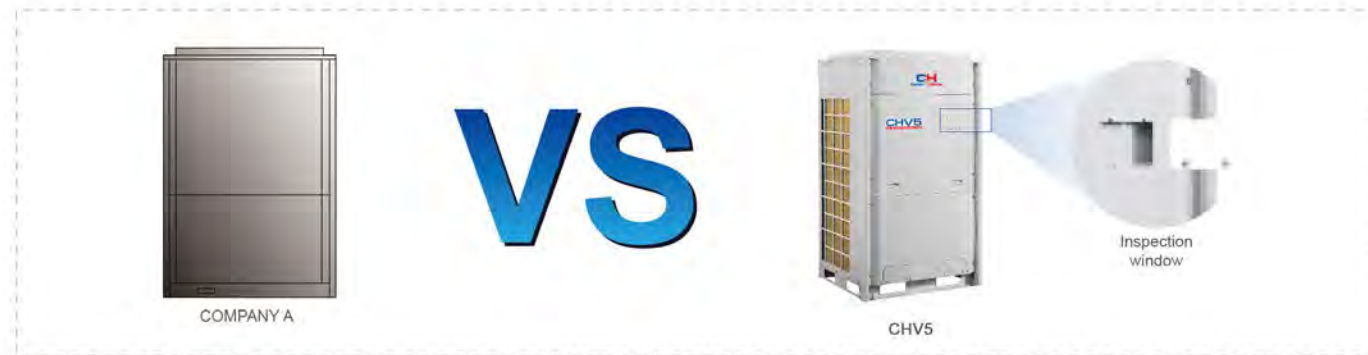

## Flexible Wiring

Common wire can meet the communication demand with no need of specialized communication wire. Common sheath twisted pair cable can be used as there is no polarity requirement.



## Auto Addressing of Outdoor and Indoor Unit

CAN network is adopted to achieve auto addressing of outdoor and indoor unit. It can allocate IDU and ODU addresses and detect IDU and ODU quantity, which greatly improves construction efficiency.



## Professional Hotel Functions

C&H CHV5 provides hotels with unique season setting function and key-card control function.

### Season Setting

Cooling or heating mode can be deactivated during a certain season to avoid affecting unit's normal operation due to mode conflict.

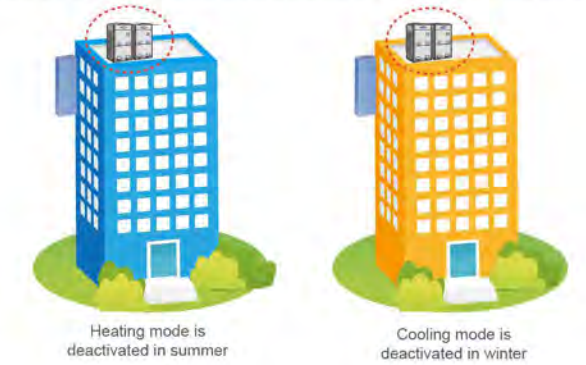















### Key-card Control for Hotel Management

The unit can be turned on or off by inserting or removing the key-card. When the key-card is removed, the system can remember all the setting and stop operation. When the key-card is inserted back, the system will be under standby mode or operate according to the status before removing key-card. It is well suited to hotels, restaurants, etc.



# SPECIFICATIONS & PARAMETER OF OUTDOOR UNITS

## Outdoor Units Lineup

MODEL	CHV-5S224NMX (8HP)	CHV-5S280NMX (10HP)	CHV-5S335NMX (12HP)	CHV-5S400NMX (14HP)	CHV-5S450NMX (16HP)
	●				
		●			
			●		
				●	
					●
	●	●			
		●●			
		●	●		
		●		●	
		●			●
			●		●
				●	●
					●●
		●●		●	
		●●			●
		●	●		●
		●		●	●
		●			●●
			●		●●
				●	●●
					●●
		●●		●	●
		●●			●●
		●	●		●●
		●		●	●●
		●			●●
			●		●●
				●	●●
					●●

## Specifications of Outdoor Units

380~415V,50/60Hz

Model		CHV-5S224NMX	CHV-5S280NMX	CHV-5S335NMX	CHV-5S400NMX	CHV-5S450NMX	CHV-5S504NMX <sup>*1</sup>	CHV-5S560NMX <sup>*1</sup>	CHV-5S615NMX <sup>*1</sup>	
Capacity range	HP	8	10	12	14	16	18	20	22	
Capacity	Cooling	kW	22.4	28	33.5	40	45	50.4	56	61.5
	Heating	kW	25	31.5	37.5	45	50	56	63	69
EER	kW/kW	4.70	4.76	4.52	4.20	3.96	4.66	4.41	4.10	
COP	kW/kW	5.0	5.28	4.46	4.18	4.07	4.59	4.44	4.13	
Power supply	V/Ph/Hz	380~415V-3Ph-50/60Hz								
Max. Circuit/Fuse Current	A	14.5/20	19.3/25	22.7/32	26.5/40	30.6/40	33.9/40	40.3/50	45/50	
Power consumption	Cooling	kW	4.8	5.88	7.41	9.52	11.36	10.82	12.70	15
	Heating	kW	5.0	5.97	8.41	10.77	12.29	12.20	14.19	16.71
Maximum drive IDU NO.	unit	13	16	19	23	26	31	34	38	
Refrigerant Charge volume	kg	5.9	6.7	8.2	9.8	10.3	12.7	13	13.5	
Sound pressure level	dB(A)	60	61	63	63	63	65	66	66	
Connecting pipe	Liquid	mm	Φ9.52		Φ12.7			Φ15.9		
	Gas	mm	Φ19.05	Φ22.2	Φ25.4		Φ28.6			
	Oil balance	mm	Φ9.52			Φ9.52				
Dimension (W*D*H)	Outline	mm	930*765*1605		1340*765*1605			1340*765*1740		
	Package	mm	1010*840*1775		1420*840*1775			1420*840*1910		
Net weight/Gross weight	kg	225/235	225/235	285/300	360/375	360/375	400/415	400/415	400/415	
Loading quantity	40' GP	set	24	24	16	16	16	16	16	
	40' HQ	set	24	24	16	16	16	16	16	

208/230V, 60Hz

Model		CHV-5S224NMF	CHV-5S280NMF	CHV-5S335NMF	CHV-5S400NMF	CHV-5S450NMF	CHV-5S504NMF	CHV-5S560NMF <sup>*1</sup>	CHV-5S615NMF <sup>*1</sup>		
Capacity range	HP	8	10	12	14	16	18	20	22		
Capacity	Cooling	kW	22.4	28	33.5	40	45	50.4	56	61.5	
	Heating	kW	25	31.5	37.5	45	50	56	63	69	
EER	kW/kW	4.70	4.76	4.52	4.20	3.96	4.66	4.41	4.10		
COP	kW/kW	5.0	5.28	4.46	4.18	4.07	4.59	4.44	4.13		
Power supply	Cooling	V/Ph/Hz	208/230V-3Ph-60Hz								
MCA	A	36	38	43	60	65	68	74	45		
MOP	A	60	60	60	80	90	93	103	112		
Power consumption	Cooling	kW	4.8	5.88	7.41	9.52	11.36	10.82	12.70	15	
	Heating	kW	5.0	5.97	8.41	10.77	12.29	12.20	14.19	16.71	
Maximum drive IDU NO.	unit	13	16	19	23	26	31	34	38		
Refrigerant Charge volume	kg	5.9	6.7	8.2	9.8	10.3	12.7	13	13.5		
Sound pressure level	dB(A)	60	61	63	63	63	65	66	66		
Connecting pipe	Liquid	mm	Φ9.52		Φ12.7			Φ15.9			
	Gas	mm	Φ19.05	Φ22.2	Φ25.4		Φ28.6				
	Oil balance	mm	Φ9.52			Φ9.52					
Dimension (W*D*H)	Outline	mm	930*765*1605		1340*765*1605			1340*765*1740			
	Package	mm	1010*840*1775		1420*840*1775			1420*840*1910			
Net weight/Gross weight	kg	225/235	225/235	285/300	360/375	360/375	400/415	400/415	400/415		
Loading quantity	40' GP	set	24	24	16	16	16	16	16		
	40' HQ	set	24	24	16	16	16	16	16		

440~460V,60Hz

Model		CHV-5S224NMU <sup>*1</sup>	CHV-5S280NMU <sup>*1</sup>	CHV-5S335NMU <sup>*1</sup>	CHV-5S400NMU <sup>*1</sup>	CHV-5S450NMU <sup>*1</sup>	CHV-5S504NMU <sup>*1</sup>	CHV-5S560NMU <sup>*1</sup>	CHV-5S615NMU <sup>*1</sup>		
Capacity range	HP	8	10	12	14	16	18	20	22		
Capacity	Cooling	kW	22.4	28	33.5	40	45	50.4	56	61.5	
	Heating	kW	25	31.5	37.5	45	50	56	63	69	
EER	kW/kW	4.54	4.60	4.36	4.05	3.82	4.50	4.26	3.96		
COP	kW/kW	4.83	5.10	4.30	4.03	3.93	4.43	4.28	3.99		
Power supply	Cooling	V/Ph/Hz	440~460V-3Ph-60Hz								
MCA	A	19	20	24	32	35	37	40	43		
MOP	A	30	30	35	40	40	45	50	55		
Power consumption	Cooling	kW	5.4	7.3	8.7	10.85	12.9	14.9	18.9	22.3	
	Heating	kW	5.8	7.65	9.35	11.45	13.3	14.6	17.5	21.8	
Maximum drive IDU NO.	unit	13	16	19	23	26	31	34	38		
Refrigerant Charge volume	kg	8.5	6.7	8.2	9.8	10.3	12.7	13	13.5		
Sound pressure level	dB(A)	60	61	63	63	63	65	66	66		
Connecting pipe	Liquid	mm	Φ9.52		Φ12.7			Φ15.9			
	Gas	mm	Φ19.05	Φ22.2	Φ25.4		Φ28.6				
	Oil balance	mm	Φ9.52			Φ9.52					
Dimension (W*D*H)	Outline	mm	930*765*1605		1340*765*1605			1340*765*1740			
	Package	mm	1010*840*1775		1420*840*1775			1420*840*1910			
Net weight/Gross weight	kg	225/235	225/235	285/300	360/375	360/375	400/415	400/415	400/415		
Loading quantity	40' GP	set	24	24	16	16	16	16	16		
	40' HQ	set	24	24	16	16	16	16	16		

Note:  
\*1: This product is under development. The parameters are estimated, please refer to the value on the nameplate.



# CHV5 Mini & Slim



## Key Features

### All DC Inverter Technology to Improve Compression Efficiency

All DC inverter compressor and high-performance high pressure chamber are adopted to reduce loss of overheat and improve compression efficiency from direct intake. Compared with low pressure chamber, the compression efficiency is improved. High-efficient permasyn motor is adopted to provide better performance than traditional DC inverter compressor.

### All DC Inverter Compressor

- All DC inverter compressor is used in this system. It can directly intake gas to reduce loss of overheat and improve efficiency.



- High-efficient permasyn motor is adopted to provide better performance than traditional DC inverter compressor.



### Technology of Maximum Torque TControl with Minimum Current

It can reduce energy loss caused by device winding so as to realize higher efficiency.

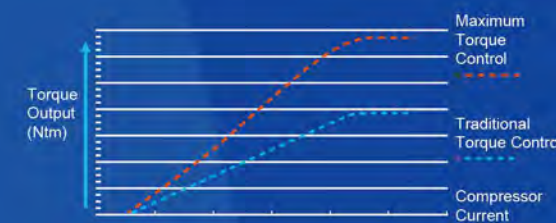

### 180° Sine Wave DC Speed Varying Technology

It can satisfy various places' demands for different temperature and is able to save a great deal of electricity and provide users with utmost comfort at the same time.

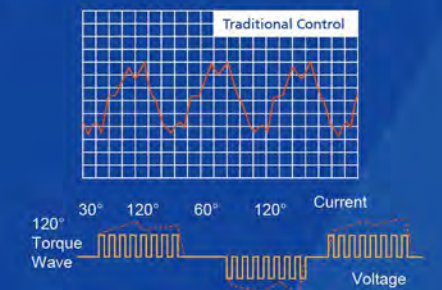

### Low-frequency Torque Control

It can directly control motor torque, through which fan motor can run at a low speed. Users will feel more comfortable while requirements of the system are also met.

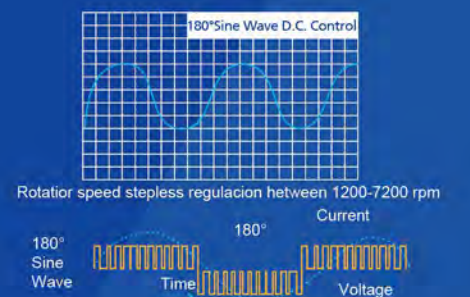
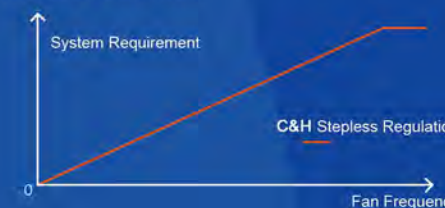

## Sensorless DC Inverter Fan Motor

- Stepless speed regulation ranges from **5Hz** to **44Hz**. Compared with traditional inverter motors, the operation is more energy-saving.

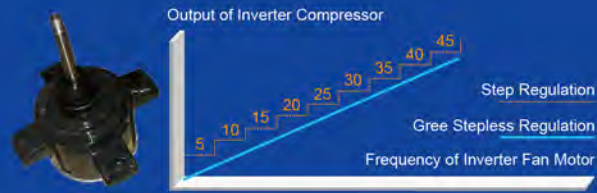

- Sensorless control technology guarantees lower noise, less vibration and steadier operation.

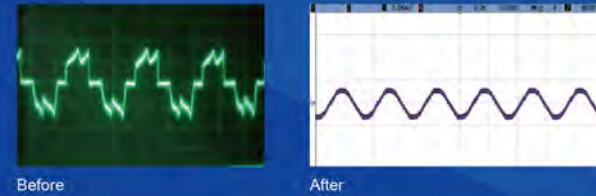

## Sensorless DC Inverter Fan Motor

The indoor unit adopts high-efficiency brushless DC motor. Compared with conventional motor, the efficiency of brushless DC motor is improved by more than **30%**. Meanwhile, the design of evaporation capacity flow is optimized through emulation software of refrigeration system and the heat exchange amount of evaporator is greatly improved.

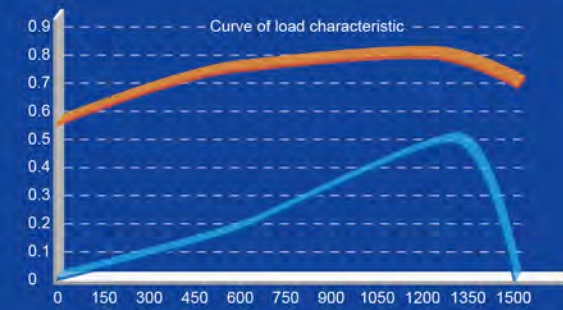

## High-efficiency Digital PFC Control \*

High-efficiency PFC control technology is adopted with efficiency improved by about 1% compared with conventional PFC. For the air conditioner with rated power of 5kW, **50W** of electricity can be saved every hour and **1.2kW** of electricity can be saved every day.

\*This feature is applicable for CHV5 Mini only.

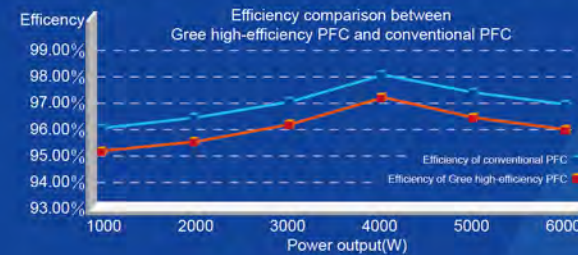

## Wider Operation Condition Range

The unit adopts DC motor with more accurate high pressure control, which effectively solves the high pressure control problem in low ambient temperature cooling. So the operation range in cooling is wider.

Company A	C&H CHV5 Mini	C&H CHV5 Slim
Cooling: 10~48°C Heating: 20~27°C	Cooling: -15~48°C Heating: 25~27°C	Cooling: -15~50°C Heating: 25~27°C

## Comfortable and Quiet Mode

### Low Noise of Outdoor Unit

- The advanced sub-cooling control technology is applied to reduce the liquid flow noise of indoor unit in cooling operation.
- Noise of outdoor unit can be as low as 45dB thanks to noise optimized design of fan system and compressor system, and multiple kinds of quiet modes of outdoor unit.



### Low Noise of Indoor Unit

- The pioneering and patented high-efficiency centrifugal fan blade and low-noise volute are adopted. Meanwhile, the imported silent valve is adopted to reduce noise of entire unit as low as 22db(A).

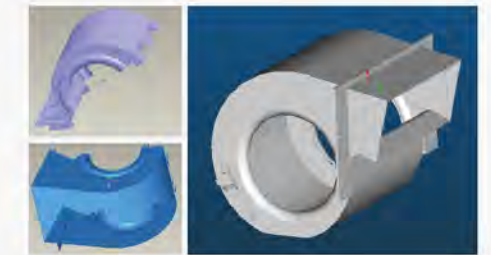

- By adopting the optimal inlet angle of centrifugal fan blade and optimal diameter ratio between internal and external circles of impeller, the air volume is increased and fan noise is decreased greatly.

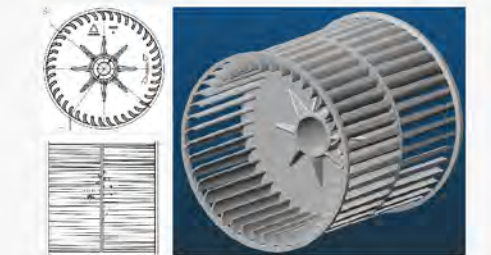

- The advanced supercooling control technology and the oil-return technology under heating mode has efficiently solved the problem of liquid flow noise of indoor unit, which improved the sound quality of indoor unit.

### Intelligent Temperature Control Technology

Intelligent temperature control technology is adopted for super fast cooling or heating, so that indoor temperature will reach set temperature more quickly.



## Comfortable Heating

Advanced intelligent defrosting mode is adopted. C&H advanced intelligent defrosting mode will choose the best defrosting way according to outdoor temperature and operation status to realize intelligent defrosting, effectively improving heating effect and performance. While in traditional defrosting mode, timing defrosting is adopted, which not only affects comfort but also reduces energy efficiency.

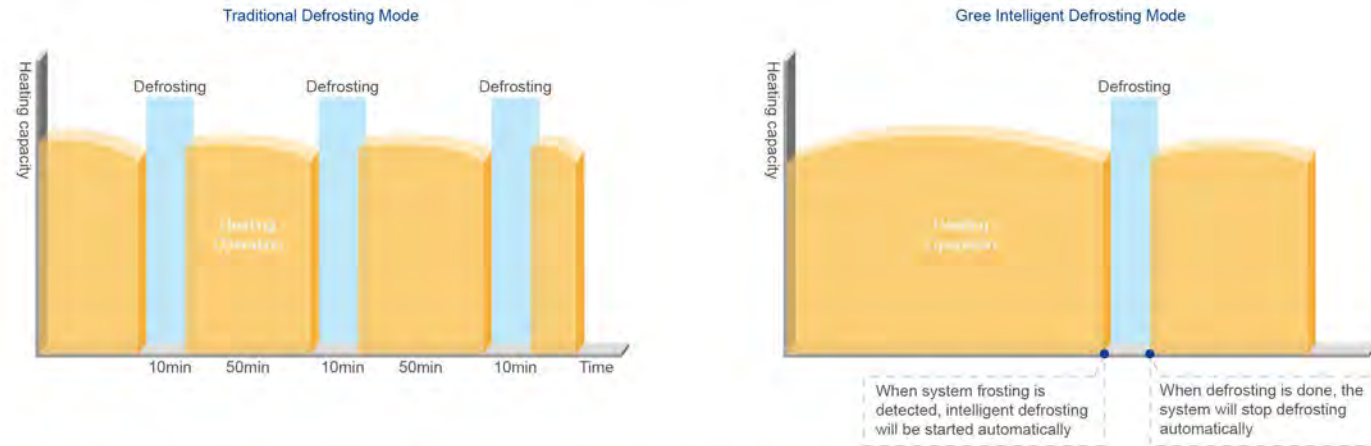

## Non-commutative Oil Return Technology in Heating

The unit can achieve non-commutative oil return in heating when outdoor ambient temperature is within 0~20°C. Thanks to this technology, indoor ambient temperature is more stable and comfort is improved in heating mode.

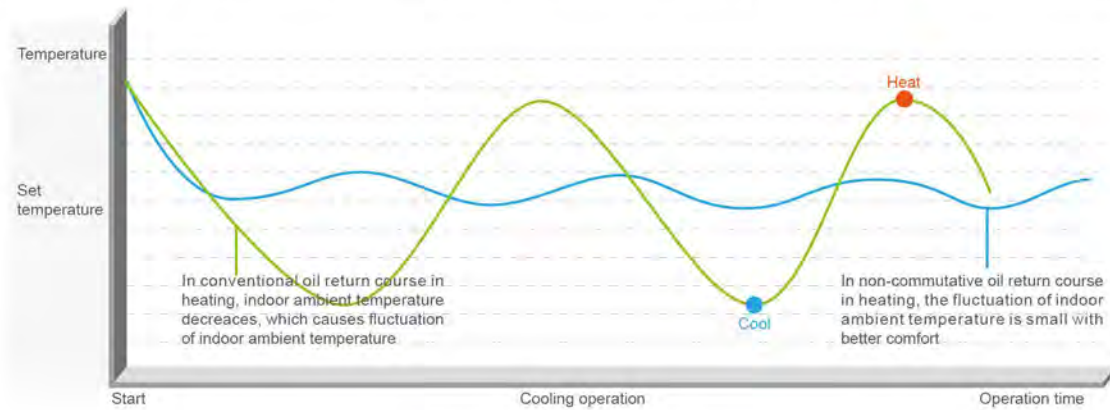

## Reliable Operation

### Compressor Closed-loop Startup Technology with More Reliable Startup

The self-innovative closed-loop startup control technology is adopted. Thanks to this technology, the startup current is small and startup is more reliable.

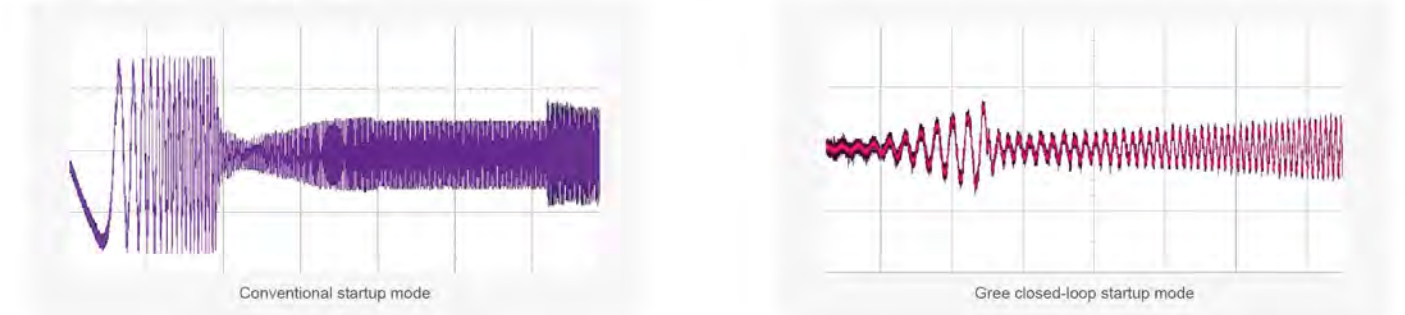

### High Anti-interference Ability

The latest CAN bus communication technology is adopted, with non-polar communication and high anti-interference ability. Common communication wire can meet the communication demand with no need of specialized shielded wire. The customers can buy the communication wire by themselves, greatly reducing installation difficulties.



### Advanced High-frequency Transformer with More Stable Voltage

- The advanced switching power supply is adopted with lower power consumption and higher power efficiency.
- Wide voltage-regulation range ensures stable voltage output when the voltage of grid fluctuates.
- Compared with conventional transformer, the size of high-frequency transformer is small and the weight is light.

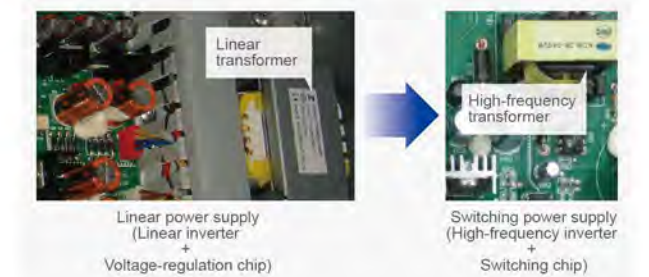

## Ultra-long Connection Pipe for More Convenient Connection

Under the subcooling control technology gained by adding subcooler, the indoor unit and outdoor unit of CHV5 mini can operate reliably with longer connection pipe.

	Company A	C&H CHV5 Slim	C&H CHV5 Mini
Total piping length	150m	300m	300m
Equivalent piping length	70m	100m	150m

## Top Advanced Light and Compact Size

CHV5 slim adopts small and compact size design. The dimension of the unit is 1430(H)×940(W) ×320(D). Compared with the normal product with the same capacity, size and weight are reduced a lot.



## Easy Installation with Lower Construction Cost

The outdoor unit of CHV5 slim is with small size and light weight. No need fork lifter and crane for movement and installation



## Movement by Stairs and Elevator

The outdoor unit of CHV5 slim is with compact and small size for saving space and easy movement. It can be carried by elevator or stairs.

## CHV5 Mini & Slim Line Up

### Mini Line up

HP	Model	Product Outlook
4	CHV-5S120NK	
5	CHV-5S140NK	
6	CHV-5S160NK	

### Slim Line up

HP	Model	Product Outlook
7	CHV-5S200SNMX	
8	CHV-5S224SNMX	
9	CHV-5S250SNMX	
10	CHV-5S280SNMX	
11	CHV-5S308SNMX	
12	CHV-5S335SNMX	

### Mini 50/60 Hz

Model		CHV-5S120NK <sup>1</sup>	CHV-5S140NK <sup>1</sup>	CHV-5S160NK <sup>1</sup>
Capacity range	HP	4	5	6
Capacity	Cooling	12.1	14	16
	Heating	14	16.5	18.5
EER	W/W	3.97	3.62	3.3
COP	W/W	4.28	4.14	3.97
Power supply		V/Ph/Hz 220~240V-1Ph-50Hz&208~230V-1Ph-60Hz		
Max. Circuit/Fuse Current	A	28.1/32	31.8/32	33.6/40
Power consumption	Cooling	3.05	3.87	4.03
	Heating	3.27	3.99	4.67
Maximum drive IDU NO.	unit	7	8	9
Refrigerant Charge volume	kg	5	5	5
Sound pressure level	dB(A)	55	56	58
Connecting pipe	Liquid	mm Φ9.52		
	Gas	mm Φ15.87		
Dimension (W*D*H)	Outline	mm 900*340*1345		
	Package	mm 998*458*1515		
Net weight/Gross weight	kg	110/120	110/120	110/120
Loading quantity	40' GP	set 57	set 57	set 57
	40' HQ	set 57	set 57	set 57

\*1 This series outdoor unit cannot match with US air handler, fresh air processing unit and high static ESP duct type unit.

### Slim 50/60 Hz

Model		CHV-5S200SNMX <sup>1</sup>	CHV-5S224SNMX <sup>2</sup>	CHV-5S250SNMX <sup>2</sup>	CHV-5S280SNMX <sup>2</sup>	CHV-5S308SNMX <sup>2</sup>	CHV-5S335SNMX <sup>2</sup>
Capacity range	HP	7	8	9	10	11	12
Capacity	Cooling	20.0	22.4	24.5	28.0	30.8	33.5
	Heating	22.4	25.0	26.0	31.5	33.9	37.5
EER	W/W	3.29	3.28	3.1	2.97	2.99	3.04
COP	W/W	4.0	4.1	3.7	3.73	3.59	3.60
IPLV	Cooling	6.1	6.1	6.0	6.0	6.0	6.0
Power supply		V/Ph/Hz 380-415-3Ph-50/60Hz					
Max. Circuit/Fuse Current	A	25	25	25	25	25	25
Power consumption	Cooling	6.08	6.83	8.0	9.4	10.3	11.0
	Heating	5.6	6.1	7.0	3.45	9.6	10.4
Maximum drive IDU NO.	unit	12	13	15	17	18	20
Refrigerant Charge volume	kg	5.5	5.5	6.0	7.5	8.0	8.0
Sound pressure level	Cooling	57	58	59	59	59	60
	Heating	58	59	60	60	60	61
Connecting pipe	Liquid	mm Φ9.52	mm Φ9.52	mm Φ9.52	mm Φ12.7	mm Φ12.7	mm Φ12.7
	Gas	mm Φ19.05	mm Φ19.05	mm Φ19.05	mm Φ25.4	mm Φ25.4	mm Φ25.4
Dimension (W*D*H)	Outline	mm 940*320*1430	mm 940*320*1430	mm 940*320*1430	mm 940*460*1615	mm 940*460*1615	mm 940*460*1615
	Package	mm 1033*433*1580	mm 1033*433*1580	mm 1033*433*1580	mm 1033*573*1765	mm 1033*573*1765	mm 1033*573*1765
Net weight/Gross weight	kg	133/144	133/144	133/144	160/175	165/180	175/185
Loading quantity	40' GP	set 54	set 54	set 54	set 44	set 44	set 44
	40' HQ	set 54	set 54	set 54	set 44	set 44	set 44

Note

① Testing conditions of rated cooling capacity: indoor 27°CDB/19°CWB, outdoor 35°CDB, connection pipe length of 5m, no height difference between units.

② Testing conditions of rated heating capacity: indoor 20°CDB, outdoor 7°CDB/6°CWB, connection pipe length of 5m, no height difference between units.

③ The total indoor unit capacity shall be within 50% to 130% of outdoor unit capacity. Correction of other parameters can be referred to the unit capacity correction sheet.

④ The above-mentioned parameters are tested with standard connection pipe length. In actual engineering, please arrange correction according to the capacity correction with long connection pipe.

\*2 This product is under development. The parameters are estimated, please refer to the value on the nameplate.



# CHV5 Heat Recovery



## Key Features

### High Efficiency

CHV5 Heat Recovery System embodies the excellent features of CHV5 (DC inverter technology, DC fan linkage control, precise control of capacity output, balancing control of refrigerant, original oil balancing technology with high pressure chamber, high-efficiency output control, low-temperature operation control technology, super heating technology, high adaptability for project, environmental refrigerant). Its energy efficiency is improved by 78% compared with conventional multi VRF.

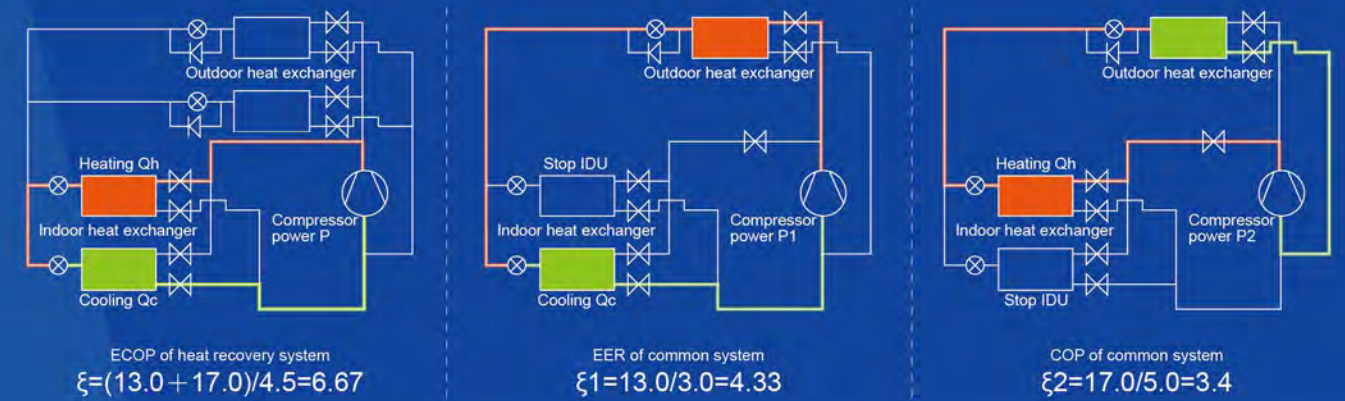

When the cooling capacity and heating capacity of common system are equivalent to the capacity of heat recovery system, its energy efficiency ratio is:

$$\xi_2 = (13.0 + 17.0) / (3.0 + 5.0) = 30.0 / 8.0 = 3.75$$

The energy efficiency ratio of heat recovery system is higher than common system:

$$(6.67 - 3.75) \times 100\% / 3.75 = 78\%$$

Note: Working conditions of above-mentioned test: outdoor temperature 7°C/6°C, indoor temperature in cooling 27°C/19°C, indoor temperature in heating 20°C/15°C.

### Five Efficient Operation Modes

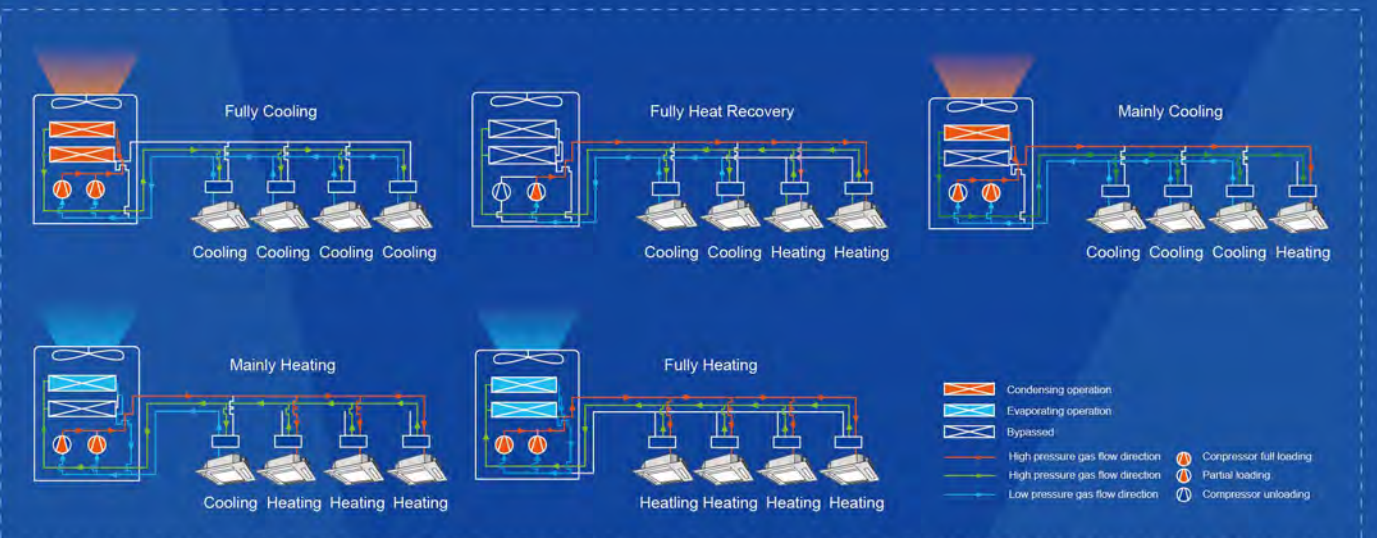

## All DC Inverter Technology to Improve Compression Efficiency

- All DC inverter compressor is used in this system. It can directly intake gas to reduce loss of overheat and improve efficiency.



- High-efficient permasyn motor is adopted to provide better performance than traditional DC inverter compressor.



- High Pressure Chamber Design

### What's high pressure chamber?

The low-temperature and low-pressure refrigerant gas inhaled from the suction inlet of compressor will change to high-temperature and high-pressure gas after compression by scroll plate. Then the gas will go out from the exhaust at the center of fixed scroll and get into the lower chamber of compressor, so that the chamber of compressor is in high temperature and high pressure.

### What's the benefits of high pressure chamber?

High pressure chamber compressor inhales directly to reduce overheat suction loss and improve compression efficiency.

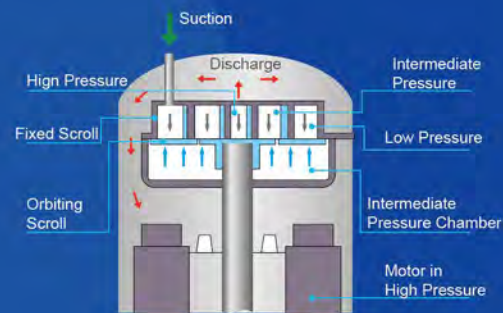

HP chamber structure can raise the high and middle frequency performance

New DC motor (concentrated winding) raises the low frequency performance

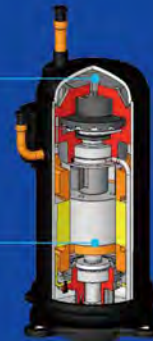

- Sensorless DC Inverter Fan Motor

Stepless speed regulation ranges from **5Hz** to **65Hz**. Compared with traditional inverter motors, the operation is more energy-saving.

Sensorless control technology guarantees lower noise, less vibration and steadier operation.

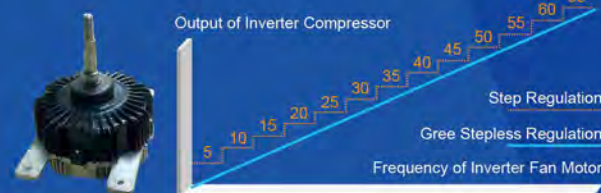

Before

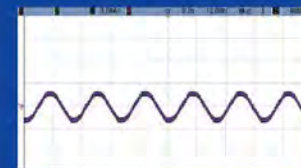

After

## Wide Range of Voltage to Ensure a Steady System Running

Working voltage range of CHV5 system has been improved to **320V-460V**, which surpasses the national standard of 342V-420V. For places with unsteady voltage, this system can still be running well.



## Wider Applicable Location

CHV5 can realize a combination of 4 outdoor unit modules connecting with as many as **80** indoor units. It's especially applicable for business building or hotels.



Max. IDU Connection: **80** sets

# Comfortable Design for A Better Life

## Intelligent Quiet Function at Night

### Quiet at night

Intelligently adjustment of outdoor fan control can minimize the noise during night time. Up to 8dB(A) can be reduced and operation noise at night is as low as 50dB(A).

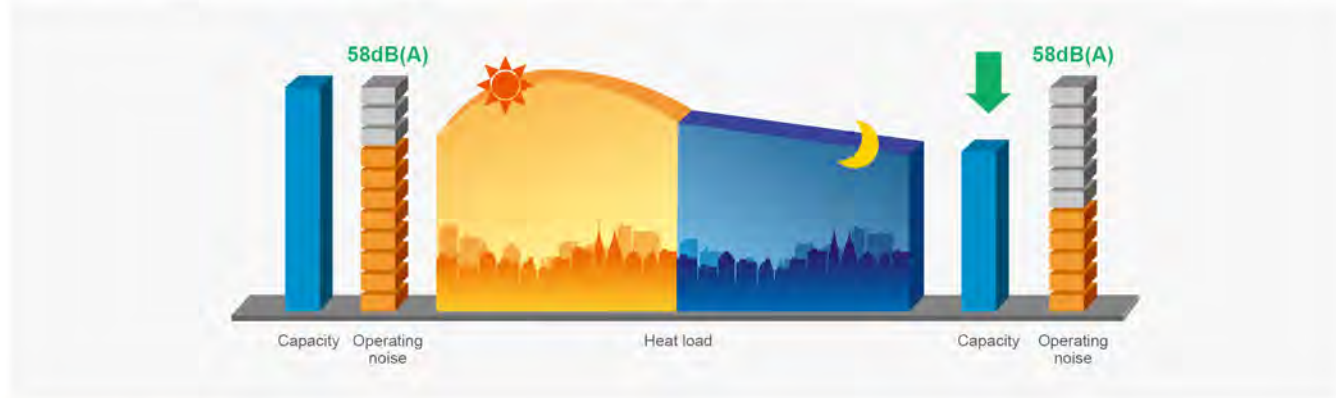

### Low noise design

HP Chamber compressor has lower exhaust pressure fluctuation so that noise is lower.

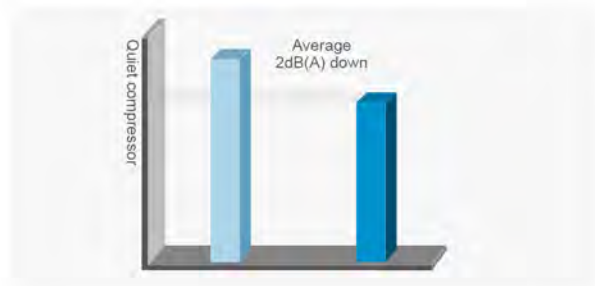

The optimized design of condensing fan blade reduces the air flow turbulence among blades, so that the noise is lower.

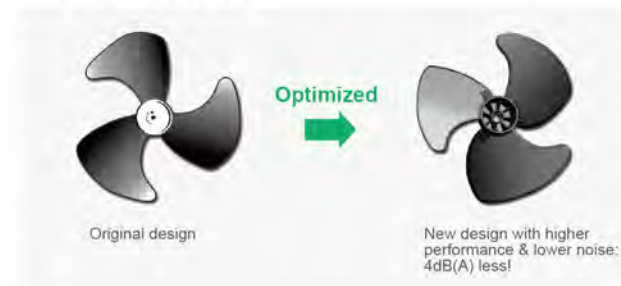

## Individual Control for More Energy Saving

The set temperature of each room may vary by the individual thermostat control of each indoor unit. The cooling and heating operation can be performed at the same time.



## Wide Operation Range

The unit can operate in wide range, greatly reducing the ambient temperature limitation.

Note: If the required capacity of indoor units is 50% higher than outdoor unit, cooling range may be lower to -15°C.

If the required capacity of indoor units is 50% higher than outdoor unit, cooling range may be up to -5°C.

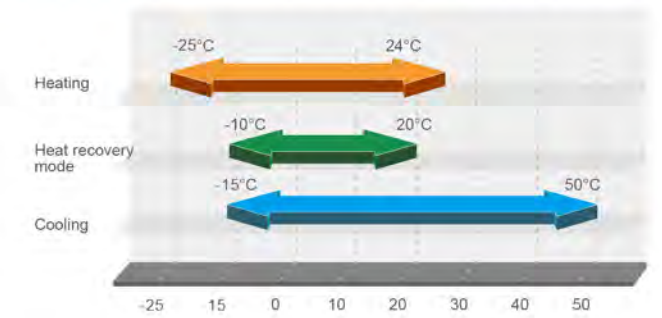

## Comfortable Heating

Advanced intelligent defrosting mode is adopted. C&H advanced intelligent defrosting mode will choose the best defrosting way according to outdoor temperature and operation status to realize intelligent defrosting, effectively improving heating effect and performance. While in traditional defrosting mode, timing defrosting is adopted, which not only affects comfort but also reduces energy efficiency.

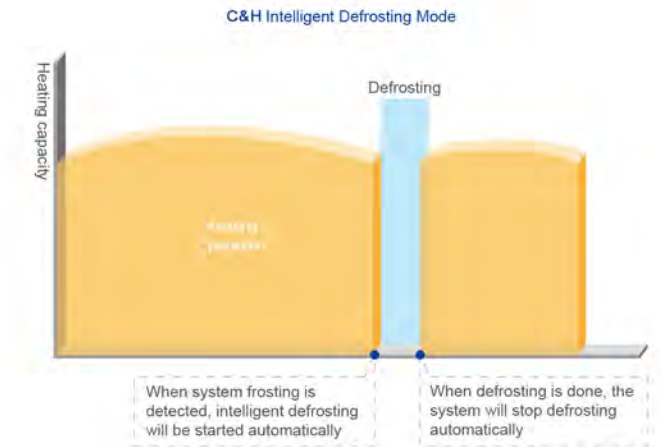
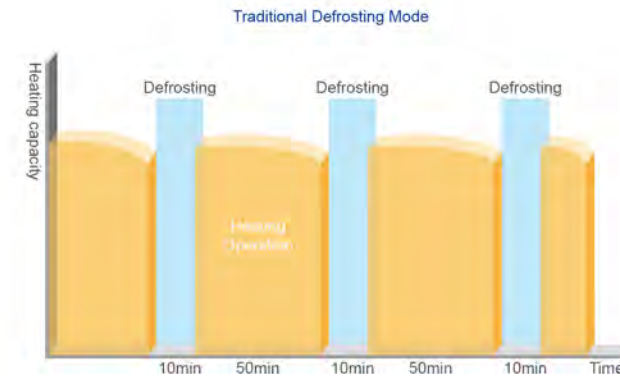

# Excellent Performance Ensured by Advanced Technology

## Modules Rotation Operating to Maximize Lifespan

### Modules 8h rotation operating

The operating priority sequence of the outdoor unit modules will be changed without restart when the system accumulatively operates for 8 hours, which can maximize the service life of the system.



## Excellent Emergency Operation Function to Ensure Reliable Operation

### Emergency Function

The CHV 5 system can realize a combination of 4 outdoor unit modules. When error is occurred to one of the modules, the others will perform the emergency operation to sustain the air conditioning.



### Emergency Operation of Compressor

All the compressors in each single module are DC Inverter based, when one compressor has error, others will perform the emergency operation.



### Emergency Operation of Fan

Double-fan design ensures that one fan can still work even if the other one has error.



## Highly Anticorrosive Golden Fins

The primary material of Golden Fins is Al-Mn(Aluminum-Manganese) anti-rust alloy, which is coated with the Golden Protection Layer (Components: Epoxy Resin & Modified Acrylic, Silicon free), the anti-corrosive performance in salt-spray testing is 200%~300% higher than normal Blue Fin\*.

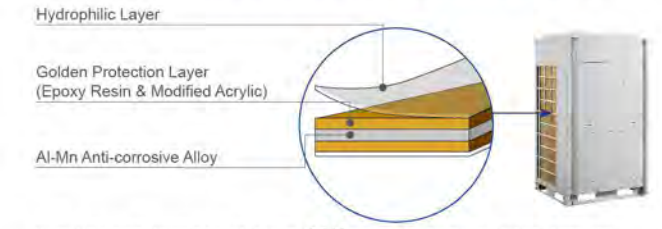

Note: Salt-spray testing result is from C&H materials chemistry testing laboratory.

## Oil Return Control Technology

### New Oil Return Control

C&H new oil return control technology effectively controls system oil return and oil storage status of each compressor, which greatly improves the operation lifespan of compressor.

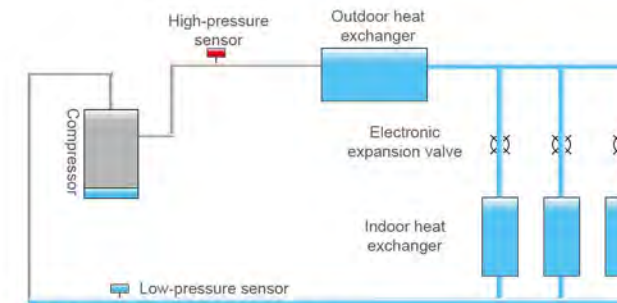

Oil storage status before oil return

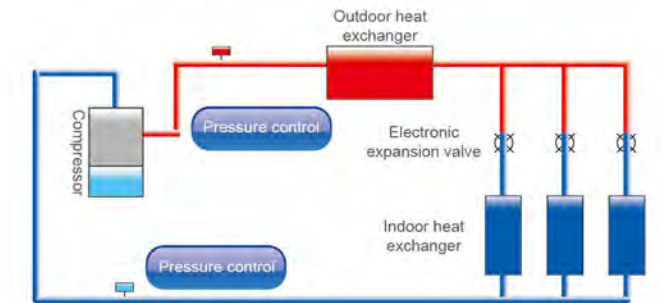

Oil return operation

### Specialized Compressor Oil Storage Control

The system applies specialized compressor oil storage technology, which can control the lowest oil level for compressor operation.

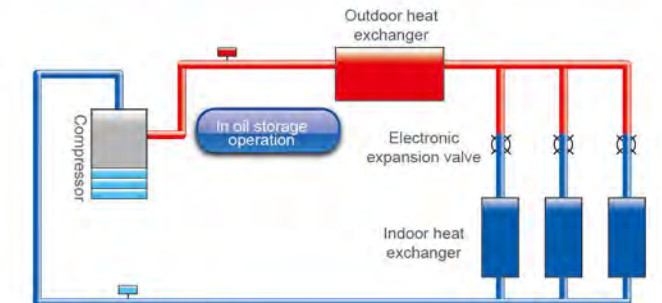

Oil storage operation

## Without External Oil-balanced Pipe Design

The unit is without external oil-balanced pipe design, reducing system pipeline connection and easy for engineering installation. The system will allocate lubricating oil of each module according to its demand, which is more intelligent, more efficient and more equal.

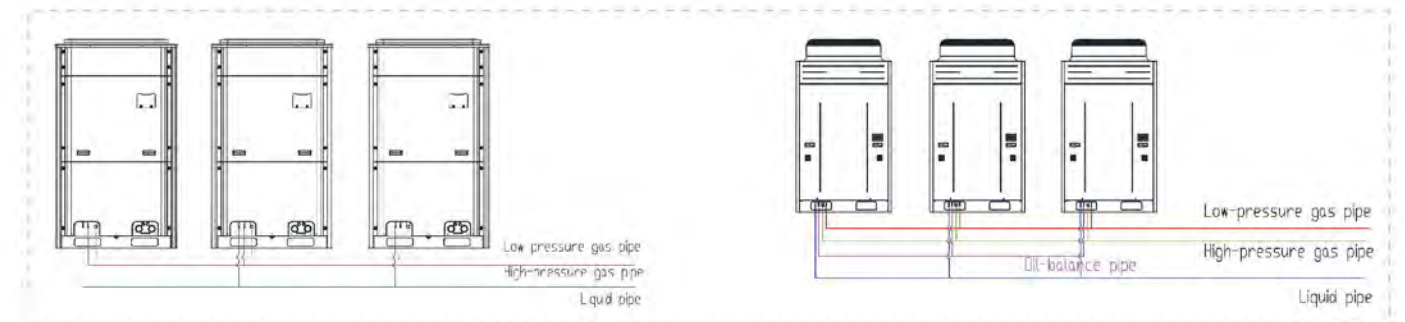

## Easy Installation and Maintenance

### Compact Design

With compact design, the outdoor unit can be carried to the roof of building through elevator, with no need of crane. It is easier for delivery and installation.



### Easy Transportation

- **Optimized base frame**

Optimized base frame, the locating and fixing of the outdoor unit during installation is more convenient and reliable.



- **Transportable by forklift**



- **Five-way piping connection**

Piping and wiring are available to the front and back, left and right, and bottom.

The five-way piping connection reduces installation difficulty and cost, improves the installation efficiency.



### Easy Maintenance

- Inspection window is available for quick checking of system operation status. No need to open panel for checking, which will be more time-saving and easier for maintenance.

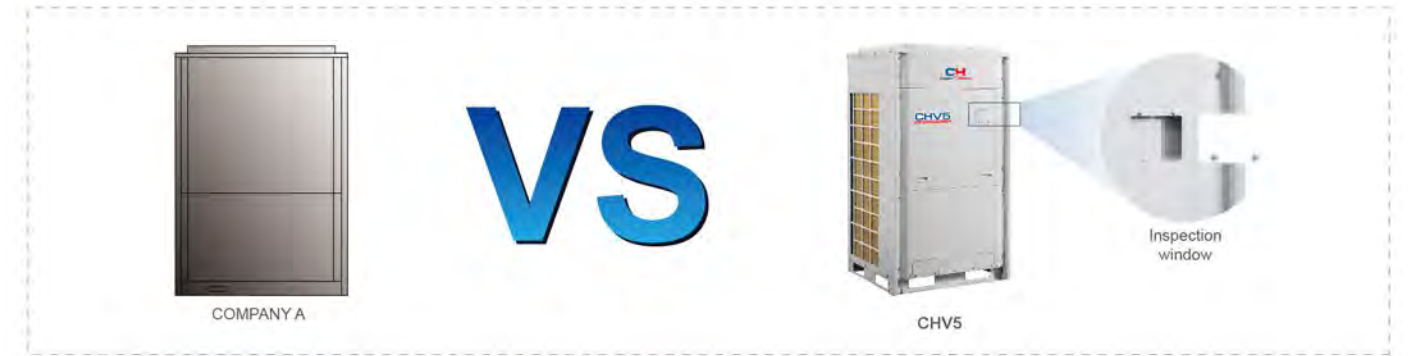

- **Error Display & Self-diagnostic Function**

Through LED display (different combinations of ON, OFF, or BLINK) on the main board, the malfunction can be judged.



# CHV5 HR Line Up

## HR Line up

HP	Model	Product Outlook
8HP	CHV-5SH224NMX	
10HP	CHV-5SH280NMX	
12HP	CHV-5SH335NMX	
14HP	CHV-5SH400NMX	
16HP	CHV-5SH450NMX	

Model	Product Outlook
HRB1NK	
HRBS4NK	
HRBS8NK	

## Specifications and Parameters

### 50/60 Hz

Model		CHV-5SH224NMX	CHV-5SH280NMX	CHV-5SH335NMX	CHV-5SH400NMX	CHV-5SH450NMX	
Capacity range	HP	8	10	12	14	16	
Capacity	Cooling	kW	22.4	28	33.5	40	
	Heating	kW	25	31.5	37.5	45	
EER	W/W	4.27	4.38	4.08	4.25	3.78	
COP	W/W	4.44	4.75	4.08	4.41	4.07	
IPLV	Cooling	kW/kW	/	/	/	/	
Power Supply	V/Ph/Hz	380~415V-3Ph-50/60Hz					
Max. circuit/fuse current	A	14.4/20	19.23/25	22.72/32	26.50/40	30.54/40	
Power consumption	Cooling	kW	5.25	6.50	8.21	9.41	11.90
	Heating	kW	5.63	6.63	9.19	10.20	12.29
Maximum drive IDU NO.	unit	13	16	19	23	26	
Refrigerant Charge volume	kg	6.2	7.1	8.6	10.2	10.5	
Sound pressure level	dB(A)	60	61	63	63	63	
Connecting pipe	Liquid	mm	Φ9.52		Φ12.7		
	Gas(Low pressure)	mm	Φ19.05	Φ22.2	Φ25.4		
	Gas(High pressure)	mm	Φ19.05		Φ22.2		
Dimension (W*D*H)	Outline	mm	930*765*1805		1340*765*1805		
	Package	mm	1010*840*1775		1420*840*1775		
Net weight/Gross weight	kg	233/243	233/243	303/318	360/375	380/375	
Loading quantity	40' GP	set	24	24	16	16	
	40' HQ	set	24	24	16	16	

### 50 Hz

Model		HRB1NK	HRBS4NK	HRBS8NK
Max.IDU Branches	unit	1	4	8
No. of connectable IDU of each branch	unit	8	8	8
Total Connectable IDU	unit	8	32	64
Max. Capacity of each branch	kW/kW	14	14	14
Max. Capacity of connectable IDU	kW/kW	14	45	65
Power supply	V/Ph/Hz	220-240V-1Ph-50Hz		
Power consumption	W	20	30	30
Maximum drive IDU NO.	unit	1	4	8
Outdoor Unit Piping Connection	Liquid	mm	Φ9.52	Φ12.7
	Gas(Low pressure)	mm	Φ15.9	Φ22.2
	Gas(High pressure)	mm	Φ19.05	Φ28.6
Indoor Unit Piping Connection	Liquid	mm	Φ9.5	Φ9.5
	Gas	mm	Φ15.9	Φ15.9

# Key Features of Indoor Units

## High Static Pressure Duct Type Indoor Unit



- High static pressure design**  
 Static pressure can be up to 150Pa, especially suitable for places in need of long distance airflow.
- Easy maintenance**  
 The system has maintenance port for easy maintenance.

- Convenient installation**  
 You can choose circular air duct or rectangular air duct according to actual needs. Or you can choose different ways of air return.
- Protection function**  
 Anti-freezing protection, fan motor overload protection, temperature sensor malfunction protection.

## Low Static Pressure Duct Type Indoor Unit



- **Low static pressure, low noise**

Especially suitable for rooms of compact structure or small installation space. Also, it provides you with a comfortable and quiet living environment.

- **Intelligent drainage device**

Water height difference up to 1.0m, which can effectively drain out condensing water and save space.

Note: Please specify if you need this function.

- **Convenient installation**

Tab type plastic filter, detachable fan motor, independent water pump assembly and electric box assembly, all for convenient maintenance.

- **Protection function**

Water overflow protection, anti-freezing protection, fan motor overload protection, temperature sensor malfunction protection.

## Slim Ducted Type Indoor Unit



- **Highly Efficient & Energy-saving**

High-efficiency DC brushless motor is used. Its efficiency is improved by over 30% compared with common motor. Evaporator flow path adopts simulating optimized design via the refrigeration system simulation software, which has greatly increased the heat exchange capacity of evaporator.

- **Slim & Small**

The unit is only 200mm's thick and 450mm's deep. Suspended ceiling doesn't have to be very high. It is suitable for ordinary rooms.

- **Wiring of Electric Control Box**

Mounting board of electric control box elements are arranged at both sides of the mounting board of fan motor. There is a wire-cross notch on each side so that wiring at both sides of the mounting board of fan motor is convenient and efficient. Strong and weak current are also separated to ensure the effectiveness of weak current signal transmission.

- **Protection Functions**

Anti-freezing protection, fan motor built-in overload protection, temperature sensor error protection

- **Ultra-quiet**

High-efficiency centrifugal fan and ultralow noise volute are developed with ANSYS and Fluent. They have also gained national patents. Meanwhile, inlet mute valve is adopted so that noise of the complete unit is greatly reduced.

- **Fast & Strong**

Intelligent temperature control technology is adopted. Cooling/ Heating function is fast and strong so that room temperature can quickly reach set temperature.

- **Flexible Installation**

Based on the requirements of building and utilization, different ways of air return and different air supply static pressure can be selected.

- **CAN Bus Communication Technology**

System response speed is faster and communication is more reliable. Auto addressing, non-polar communication, free wire matching

- **Convenient Operation & Maintenance**

Electric control box is attached independently so that it can be detached as a whole, which is convenient for maintenance. The installation and maintenance of fan and motor is also convenient.

## 4-way Cassette Indoor Unit



- Strong and balanced airflow**  
 Unit features auto operation, 4-way airflow, 7 fan speeds and strong circulating airflow.
- DC inverter motor**  
 With good speed regulation performance, motor efficiency improved by 30% v.s. normal motor.
- Ultra-low noise operation**  
 DC inverter motor can realize stepless speed regulation to lower noise. Indoor unit can be set to work under auto quiet mode via wired controller.
- Intelligent drainage device**  
 Water height difference up to 1.0m, which can effectively drain out condensing water and save space.
- Protection function**  
 Water overflow protection, anti-freezing protection, temperature sensor malfunction protection, fan motor overload protection.

## Compact 4-way Cassette Indoor Unit



- Compact Design for Easy Installation**  
 Units maintain the uniform length and width with consistent ceiling opening and panel dimension, convenient for design and installation;
- Ultra-low noise operation**  
 DC inverter motor can realize stepless speed regulation to lower noise. Indoor unit can be set to work under auto quiet mode via wired controller.
- Intelligent drainage device**  
 Water height difference up to 1.0m, which can effectively drain out condensing water and save space.



## 2-way Cassette Indoor Unit



- Beautiful Appearance**  
 With beautiful and elegant front panel, it is congenial to the indoor surroundings.
- Intelligent drainage device**  
 Water height difference up to 1.0m, which can effectively drain out condensing water and save space.
- Two-way air flow design**  
 Two-way air outlet, to stretch air outlet distance and solve air supply problem of elongated room
- Multiple protections**  
 Anti-freezing protection, temperature malfunction protection, fan motor overload and humidity sensor protection.

## 1-way Cassette Indoor Unit



- Small installation space**  
 With 185mm ultrathin design, unit can be installed in the ceiling of 19cm deep.
- Detachable grille and long life filter**  
 Grille is detachable for easy cleaning. With durable filter, cleaning cycle is 20 times longer.
- High drain pump lift**  
 Drain pump lift reaches 1.0m, which can effectively drain out water.
- Protection function**  
 Water overflow protection, anti-freezing protection, fan motor overload protection, temperature sensor malfunction protection.

## Wall-mounted Indoor Unit



- **Comfortable and balanced airflow, up&down air outlet**

Up air outlet: In cooling, cool air blows out horizontally and then gradually drops.

Down air swing: In heating, warm air blows downward and then gradually climbs up.

- **Triple defenders for better purification**

Mildew-proof filter, electrostatic fibre and anti-biotic fibre adopted to remove dust, smell, bacteria and mildew.

- **Cold air prevention design**

During heating in winter, cold air prevention function is enabled so that air won't be blown out until it's warm.

- **Multiple protections**

Anti-freezing protection, temperature sensor malfunction protection, fan motor overload protection.

## Floor Ceiling Type Indoor Unit



- **Hoisted or seated, flexible installation**

Unit can be hoisted or seated. When seated, suspended ceiling is not needed.

- **Beautiful appearance**

With beautiful and elegant front panel, it is congenial to the indoor surroundings.

- **Protection function**

Anti-freezing protection, temperature sensor malfunction protection, fan motor overload protection.

- **Horizontal and vertical air swing**

Wider air swing range for your comfortable working and living environment.

## Console Indoor Unit



- **Multiple fan speed**

The fan can operate in multiple speed and satisfy different air flow volume requirements.

- **Detachable grille and long life filter**

Grille is detachable for easy cleaning. With long life filter, cleaning cycle is 20 times longer.

- **High drain pump lift**

Drain pump lift reaches 1.0m, which can effectively drain out water.

- **Protection function**

Water overflow protection, anti-freezing protection, fan motor overload protection, temperature sensor malfunction protection, auxiliary electric heating overheat protection(This function is not included in pure heat pump unit).

## Floor Standing Indoor Unit



- **Wide Application**

It can be widely adopted in hotels, restaurants, office, etc.

- **Auto clean to ensure a healthy life**

After turning off the unit, the indoor fan will keep running in low speed for a moment to dry the inner components and parts, in order to prevent mildew and keep user healthy.

## Fresh Air Processing Indoor Unit

Airflow volume: 1200~4000m<sup>3</sup>/h  
 Applicable range: Residential houses, villas, business buildings, hotels, apartments, etc.



### One system, two functions

- Adopted with DC inverter technology, Fresh Air DC Inverter Multi VRF System features air conditioning function and fresh air function.



### Enjoy fresh air

- Airflow volume: 1200~4000m<sup>3</sup>/h, cooling capacity: 14-45kW  
 Applicable for all kinds of structure.
- Direct evaporative cooling adopted, air conditioning+fresh air can be realized accurately and precisely.
- DC inverter technology adopted, constant humidity is enabled with less power consumption.
- Integrated system control with C&H CHV Multi VRF System.



### Air conditioning and fresh air, two in one

- Less investment**  
 Fresh Air DC Inverter Multi VRF System can be combined with C&H CHV5. For a same room, if the same amount of fresh air is to be taken, then the cost of CHV5+Fresh air unit is equivalent to the cost of CHV+Air exchange fan.
- Less operation cost**  
 Unit can control refrigerant output according to actual needs to ensure constant airflow temperature. By adjusting power output, light-load but high power operation can be avoided. Thus, operation cost can be greatly reduced.
- Less installation space**  
 Save installation space for outdoor units. Especially suitable for places that have restricted installation space.



### Air Handler

- Highly Flexible Installation**  
 The unit is designed for outdoor installation and less indoor space taking, allowing easy installation and maintenance. The unit can be installed on the ground or on the roof of the building, which means the installation is totally flexible depending on the project requirement.
- Cold Air Prevention Design**  
 When heating in winter, cold air prevention function is enabled so that air won't be blown out until it's warm.
- Long life and Washable Filter**  
 The filter is easy to be dismantled and installed. You can use dust collector or water to clear away the dust.

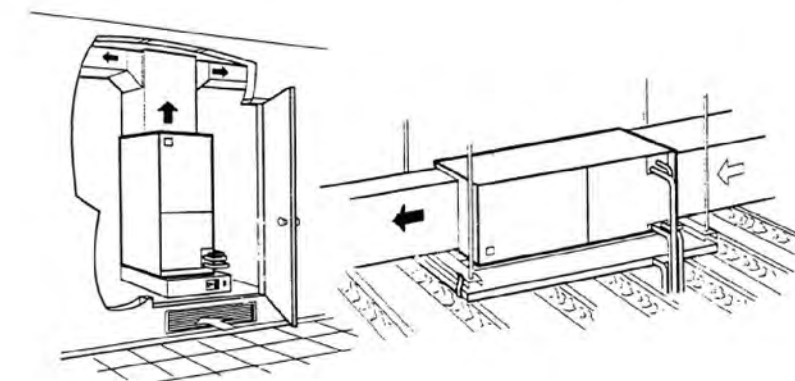

# Indoor Units Lineup

## Specifications of Indoor Units

Type of indoor unit	Specification	22	25	28	32	36	40	45	50	56	63	71	72	80	90	100	112	125	140	160	224	280	450
High Static Pressure Duct Type Indoor Unit										●	●	●		●	●	●	●	●	●	●	●	●	●
Low Static Pressure Duct Type Indoor Unit		●	●	●	●	●	●	●	●	●	●	●		●	●	●	●	●	●				
Slim Ducted Type Indoor Unit		●	●	●	●	●	●	●	●	●	●	●	●										
4-way Cassette Unit				●	●	●	●	●	●	●	●	●	●		●	●	●	●	●	●	●	●	●
Compact 4-way Cassette Indoor Unit		●	●		●	●	●	●	●	●	●	●											
2-way Cassette Indoor Unit				●	●	●	●	●	●	●	●	●											
1-way Cassette Unit		●	●	●	●	●	●	●	●														
Wall-mounted Type Unit		●	●	●	●	●	●	●	●	●	●	●											
Floor Ceiling Type Indoor Unit				●	●	●	●	●	●	●	●	●			●		●	●	●				
Console Indoor Unit		●	●	●	●	●	●	●															
Floor Standing Type Indoor Unit													●						●				
Fresh Air Processing Indoor Unit																				●	●	●	●
Air handler												●	●	●	●	●			●				

## High Static Pressure Duct Type Indoor Unit 50/60 Hz

Model		CHV-5SDH56NK	CHV-5SDH63NK	CHV-5SDH71NK	CHV-5SDH80NK	CHV-5SDH90NK	
Capacity	Cooling	kW	5.6	6.3	7.1	8.0	9.0
	Heating	kW	6.3	7.1	8.0	9.0	10.0
Power supply	V/Ph/Hz		220~240/1/50 & 208~230/1/60				
Power consumption	W	120	120	130	130	200	
Airflow volume(H/M/L)	m <sup>3</sup> /h	1000/800/600	1000/800/600	1100/900/700	1100/900/700	1700/1450/1100	
	CFM	590/471/355	590/471/355	650/530/410	650/530/410	1000/853/650	
Rated Current <sup>2</sup>	Cooling	A	0.6	0.6	0.6	0.6	1.0
	Heating	A	0.6	0.6	0.6	0.6	1.0
	Water Heating	A	/	/	/	/	/
ESP	Pa	70/0~100					
Sound pressure level(H/M/L)	dB(A)	44/40/36	44/40/36	45/41/37	45/41/37	46/44/42	
Connecting pipe diameter	Liquid	mm	Φ9.52	Φ9.52	Φ9.52	Φ9.52	Φ9.52
	Gas	mm	Φ15.9	Φ15.9	Φ15.9	Φ15.9	Φ15.9
Drain pipe	External dia.	mm	Φ25	Φ25	Φ25	Φ25	Φ25
	Thickness	mm	2.5	2.5	2.5	2.5	2.5
Dimension (WxDxH)	Outline	mm	1271x558x268			1229x775x290	
	Package	mm	1348x597x283			1338x877x305	
Net weight/Gross weight	kg	35/40	35/40	35/40	35/40	47/54	
Loading	40' GP	set	192	192	192	128	
	40' HQ	set	216	216	216	128	

Model		CHV-5SDH100NK	CHV-5SDH112NK	CHV-5SDH125NK	CHV-5SDH140NK	CHV-5SDH160NK	CHV-5SDH224NK	CHV-5SDH280NK	
Capacity	Cooling	kW	10.0	11.2	12.5	14.0	16.00	22.4	28.0
	Heating	kW	11.2	12.5	14.0	16.0	18.00	25.0	31.0
Power supply	V/Ph/Hz		220~240/1/50 & 208~230/1/60				220~240/1/50/60	220~240/1/50 & 208~230/1/60	
Power consumption	W	200	200	220	220	560	800	900	
Airflow volume(H/M/L)	m <sup>3</sup> /h	1700/1450/1100	1700/1450/1100	2000/1550/1200	2000/1700/1400	3100	4000	4400	
	CFM	1000/853/650	1000/853/650	1175/912/706	1175/1000/824	1824	2355	2590	
Rated Current <sup>2</sup>	Cooling	A	1.0	1.0	1.0	1.0	4	4.1	4.6
	Heating	A	1.0	1.0	1.0	1.0	4	4.1	4.6
	Water Heating	A	/	/	/	/	/	/	/
ESP	Pa	70/0~100					50	150/50~200	150/50~200
Sound pressure level(H/M/L)	dB(A)	46/44/42	46/44/42	48/45/42	48/46/44	55.0	54.0	55.0	
Connecting pipe diameter	Liquid	mm	Φ9.52	Φ9.52	Φ9.52	Φ9.52	Φ9.52	Φ9.52	
	Gas	mm	Φ15.9	Φ15.9	Φ15.9	Φ15.9	Φ19	Φ22.2	Φ22.2
Drain pipe	External dia.	mm	Φ25	Φ25	Φ25	Φ25	Φ30	Φ30	
	Thickness	mm	2.5	2.5	2.5	2.5	1.5	1.5	
Dimension (WxDxH)	Outline	mm	1229x775x290			1497x799x389	1483x791x385	1686x870x450	
	Package	mm	1338x877x305			1578x883x400	1758x883x470	1788x988x580	
Net weight/Gross weight	kg	47/54	47/54	47/54	47/54	79/103	82/104	105/140	
Loading	40' GP	set	128	128	128	128	75	65	
	40' HQ	set	128	128	128	128	75	65	

## Low Static Pressure Duct Type Indoor Unit 50/60 Hz

Model		CHV-5SD22NK	CHV-5SD25NK	CHV-5SD28NK	CHV-5SD32NK	CHV-5SD36NK	
Capacity	Cooling	kW	2.2	2.5	2.8	3.2	3.6
	Heating	kW	2.5	2.8	3.6	3.6	4.0
Power supply	V/Ph/Hz		220~240/1/50 & 208~230/1/60				
Power consumption	W	35	35	35	43	43	
Airflow volume(H/M/L)	m <sup>3</sup> /h	450/350/250	450/350/250	450/350/250	550/450/350	550/450/350	
	CFM	265/206/147	265/206/147	265/206/147	325/265/206	325/265/206	
Rated Current <sup>2</sup>	Cooling	A	0.2	0.2	0.2	0.2	0.2
	Heating	A	0.2	0.2	0.2	0.2	0.2
	Water Heating	A	/	/	/	/	/
ESP	Pa	15/0~30					
Sound pressure level(H/M/L)	dB(A)	31/28/25	31/28/25	31/28/25	32/30/27	32/30/27	
Connecting pipe diameter	Liquid	mm	Φ6.35	Φ6.35	Φ6.35	Φ6.35	Φ6.35
	Gas	mm	Φ9.52	Φ9.52	Φ9.52	Φ12.7	Φ12.7
Drain pipe	External dia.	mm	25	25	25	25	25
	Thickness	mm	2.5	2.5	2.5	2.5	2.5
Dimension (WxDxH)	Outline	mm	700 x 615 x 200				
	Package	mm	893x743x305				
Net weight/Gross weight	kg	22/27	22/27	22/27	22/28	22/28	
Loading	40' GP	set	192	192	192	192	
	40' HQ	set	192	192	192	192	





### Console Indoor Unit 50/60 Hz

Model		CHV-5SK22NK	CHV-5SK28NK	CHV-5SK36NK	CHV-5SK45NK	CHV-5SK50NK	
Capacity	Cooling	kW	2.2	2.8	3.6	4.5	5.0
	Heating	kW	2.5	3.2	4.0	5.0	5.5
Power supply	V/Ph/Hz		220-240/1/50 & 208-230/1/60				
Power consumption	W	15	15	20	40	40	
Airflow volume(H/M/L)	m <sup>3</sup> /h	400/320/270	400/320/270	480/400/310	680/600/500	680/600/500	
	CFM	235/188/159	235/188/159	282/235/182	400/353/294	400/353/294	
Rated Current <sup>2</sup>	Cooling	A	0.15	0.15	0.15	0.15	0.15
	Heating	A	0.15	0.15	0.15	0.15	0.15
	Water Heating	A	/	/	/	/	/
ESP	Pa	0	0	0	0	0	
Sound pressure level(H/M/L)	dB(A)	38/33/27	38/33/27	40/37/32	46/43/39	46/43/39	
Connecting pipe diameter	Liquid	mm	6.35	6.35	6.35	6.35	6.35
	Gas	mm	9.52	9.52	9.52	12.7	12.7
Drain pipe	External dia.	mm	17.2	17.2	17.2	17.2	17.2
	Thickness	mm	1	1	1	1	1
Dimension (WxDxH)	Outline	mm	700/215/600	700/215/600	700/215/600	700/215/600	700/215/600
	Package	mm	780x285x682	780x285x682	780x285x682	780x285x682	780x285x682
Net weight/Gross weight	kg	16/19	16/19	16/19	16/19	16/19	
Loading	40' GP	set	387	387	387	387	387
	40' HQ	set	433	433	433	433	433

### Air Handler 60 Hz

Model		CHV-5SAH71NK	CHV-5SAH90NK	CHV-5SAH100NK	CHV-5SAH112NK	CHV-5SAH140NK	
Capacity	Cooling	kW	7.1	9.0	10.0	11.2	14.0
	Heating	kW	7.1	10.0	11.0	12.5	15.0
Power supply	V/Ph/Hz		208-230/1/60				
Power consumption	W	140	170	245	245	368	
Airflow volume(H/M/L)	m <sup>3</sup> /h	1400	1680	1940	2210	2380	
	CFM	825	980	1140	1300	1400	
Rated Current <sup>2</sup>	Cooling	A	1.52	1.35	2.00	2.00	2.50
	Heating	A	1.52	1.35	2.00	2.00	2.50
	Water Heating	A	/	/	/	/	/
ESP	Pa	25	37	37	37	50	
Sound pressure level(H/M/L)	dB(A)	48	50	52	53	54	
Connecting pipe diameter	Liquid	mm	φ9.52	φ9.52	φ9.52	φ9.52	φ9.52
	Gas	mm	φ15.9	φ15.9	φ15.9	φ15.9	φ15.9
Drainage Connection Size (Outer Diameter*Wall Thickness)	mm	φ19	φ19	φ19	φ19	φ19	
Dimension (WxDxH)	Outline	mm	460*540*1105	460*540*1105	540*540*1224	540*540*1224	630*540*1224
	Package	kg	514*617*1155	514*617*1155	594*617*1274	594*617*1274	684*618*1280
Net weight/Gross weight	set	53/57	55.5/59	65/70	67/72	79/84	
Loading	40' GP	set	164	164	85	85	85
	40' HQ	set	172	172	114	114	114

### Fresh Air Processing Indoor Unit 50 Hz

Model		CHV-5SA140N(X1.2)K *	CHV-5SA224N(X2.0)M *	CHV-5SA280N(X2.5)M *	CHV-5SA280N(X3.0)M *	CHV-5SA450N(X4.0)M *	
Capacity	Cooling	kW	14.0	22.4	28.0	28.0	45.0
	Heating	kW	10.0	16.0	20.0	20.0	32.0
Power supply	V/Ph/Hz		220-240/1/50		380-415/3/50		
Power consumption	W	360	740	760	1060	1240	
Airflow volume(H/M/L)	m <sup>3</sup> /h	1200	2000	2500	3000	4000	
	CFM	705	1175	1470	1765	2355	
Rated Current <sup>2</sup>	Cooling	A	1.82	1.32	1.36	1.89	2.22
	Heating	A	1.82	1.32	1.36	1.89	2.22
	Water Heating	A	/	/	/	/	/
ESP	Pa	150		200			
Sound pressure level(H/M/L)	dB(A)	42	47	48	51	52	
Connecting pipe diameter	Liquid	mm	φ9.52	φ9.52	φ9.52	φ12.7	
	Gas	mm	φ15.9	φ19.05	φ22.2	φ22.2	φ28.6
Drain pipe	External dia.	mm	25	25	25	25	25
	Thickness	mm	2.5	2.5	2.5	2.5	2.5
Dimension (WxDxH)	Outline	mm	1483 x 756 x 300	1500 x 1000 x 500		1700 x 1100 x 850	
	Package	mm	1514x785x360	1840x1200x673		1890x1460x835	
Net weight/Gross weight	kg	63.5/71	130/182	134/188	134/188	208/266	
Loading	40' GP	set	84.0	18.0	18.0	18.0	16.0
	40' HQ	set	98.0	18.0	18.0	18.0	16.0

Note: \* This series can be matched with GMV5(Top discharge outdoor unit)only

### Floor Standing Type 50/60 Hz

Model		CHV-5SFS100NK	CHV-5SFS140NK	
Capacity	Cooling	kW	10	14
	Heating	kW	11	15
Power supply	V/Ph/Hz		220-240/1/50 & 208-230/1/60	
Power consumption	W	185	185	
Airflow volume(H/M/L)	m <sup>3</sup> /h	1850/1600/1400	1850/1600/1400	
	CFM	1089/942/824	1089/942/824	
Rated Current <sup>2</sup>	Cooling	A	1.5	1.5
	Heating	A	1.5	1.5
	Water Heating	A	/	/
ESP	Pa	0	0	
Sound pressure level(H/M/L)	dB(A)	50/48/46	50/48/46	
Connecting pipe diameter	Liquid	mm	9	9
	Gas	mm	16	16
Drain pipe	External dia.	mm	31	31
	Thickness	mm	4.5	4.5
Dimension (WxDxH)	Outline	mm	1870x580x400	1870x580x400
	Package	mm	2083/738/545	2083/738/545
Net weight/Gross weight	kg	54/74	57/77	
Loading	40' GP	set	67	67
	40' HQ	set	67	67



# Control System



## Smart Model Selection Software and Debugging Software

### Model Selection Software

C&H multi VRF selection software is a kind of advanced computer program for selecting models automatically in sales and project bidding. It integrates multi VRF selection logic and computer software to provide a user-friendly interactive interface, which is able to automatically recommend suitable models to user according to ambient condition of project and user's demand. It is applicable for CHV5.

### Flexible Setting of Project Design Conditions

When setting up a new model selection project, the information of customer, designer, unit series and working conditions, etc. can be set as relevant parameters of model selection, and then sent to data report for checking during project design.

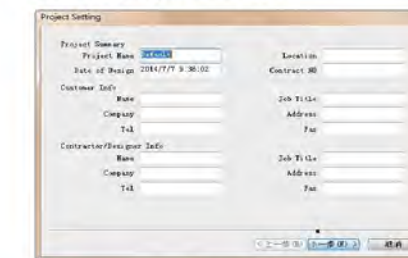

Project Setting



Project Design Conditions

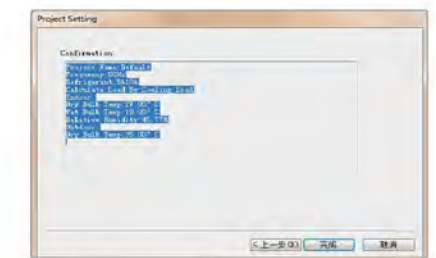

Confirmation

### Accurate Recommendation of Indoor Unit and Outdoor Unit

When selecting indoor unit model with the software, you can use automatic recommendation way only by inputting the required air conditioning load and indoor unit series. Then the software will recommend the suitable indoor unit model automatically according to model selection logic. When selecting outdoor unit model, you can use automatic recommendation way directly to select the suitable outdoor unit model.

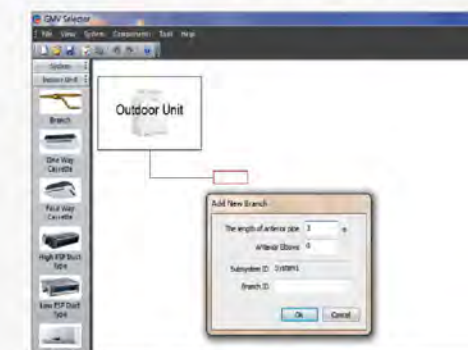

Add New Branch

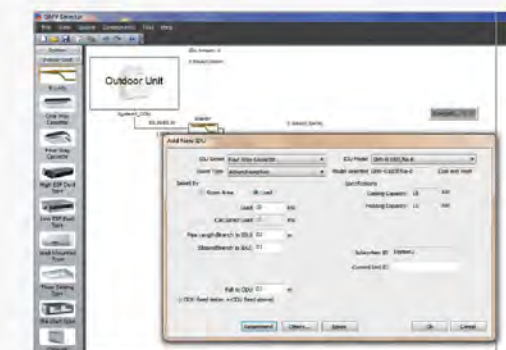

Add New IDU (1)



Add New IDU (2)

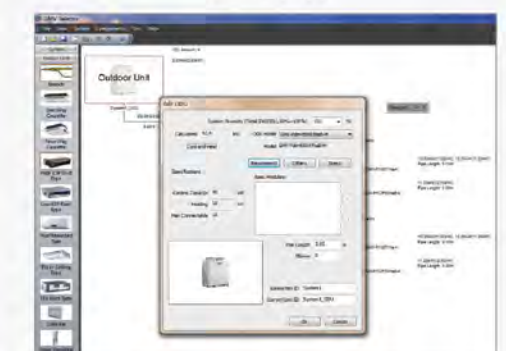

Add New ODU

### Free Modification of Selected Models

If you are not satisfied with the system recommended by the software, you can select or adjust indoor unit model through alternate selection function.

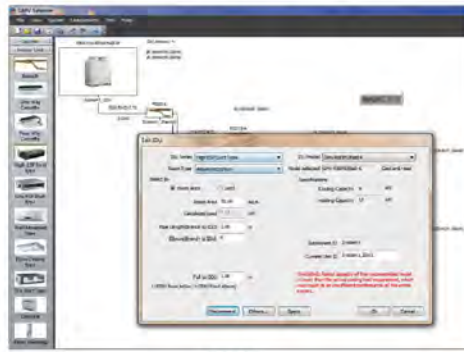

Edit IDU

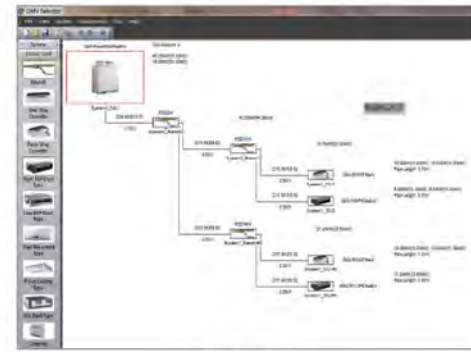

Confirmation

### One-click Modification and System Validation

When reselection is needed due to major changes of indoor units, one-click recommendation function can be adopted to reselect all indoor units with simple operation; after finishing model selection, you can use one-click system validation function to check various parameters requirements of air conditioning system.



One-click Recommendation

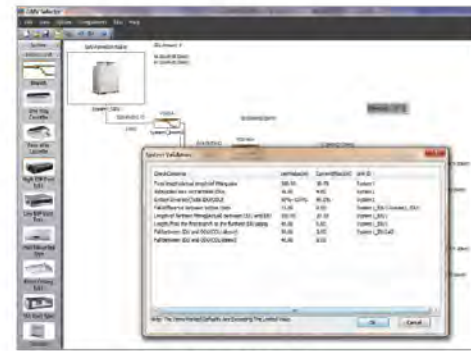

System Validation

### Optional Controller Configuration and Electric System Configuration

The software will offer controller model matched with the system. The user only needs to choose controller type and then the software will output the controller model into the report.

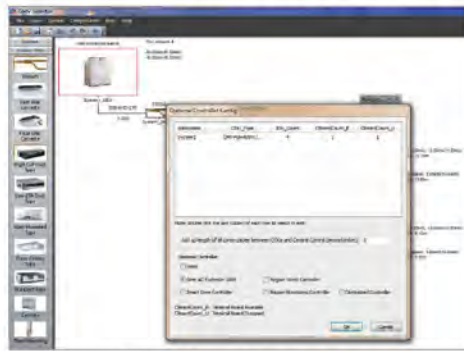

Optional Controller Configuration

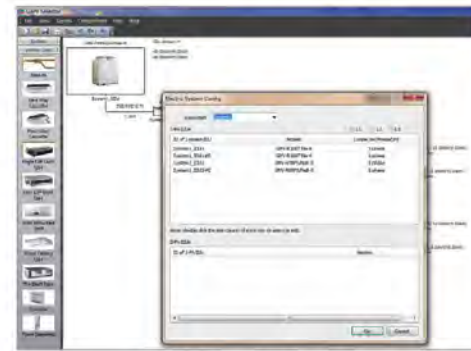

Electric System Configuration

### Save Model Selection Project, Output Data Report and System Wiring Diagram

After finishing system selection and various system configurations, the user can save model selection project freely for future reference. Then the user can output relevant parameters of selected project in an excel form and output system wiring CAD diagram for reference in installation.

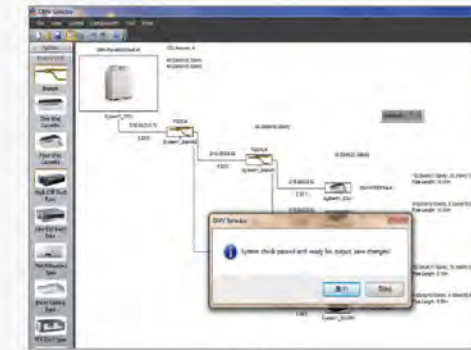

Save Data



Units Setting

Capacity (kW)	Indoor Unit (kW)	Outdoor Unit (kW)
10	10	10
15	15	15
20	20	20
25	25	25
30	30	30

Parameters Output in Excel Form

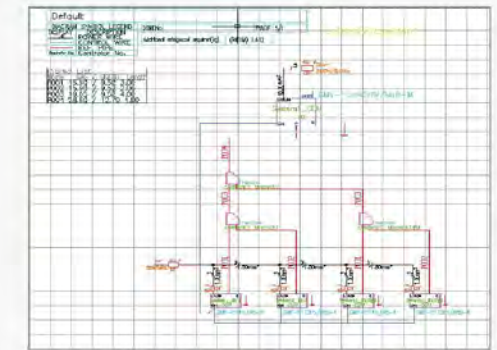

Output CAD Wiring Diagram

### Intelligent Debugging Software

CHV5 offers an intelligent debugging software to the end-users for faster construction needs.

#### Monitoring Functions

- Fully control the operation status of each device of the system;
- Hover the mouse over the parameter to display its remarks.
- The online devices will be displayed in a tree structure;
- Display the information of air conditioner in divided regions;
- Each display region can be moved or concealed;
- Display updated status of units in real time;

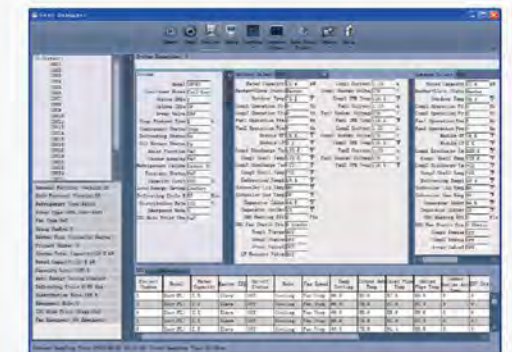

### Control Functions

- Control the operation of unit as you like;
- Comprehensive control of outdoor unit, indoor unit, water tank, hydro box, etc.;
- Real-time display of current status or status after being controlled;
- Both single control and group control are available.

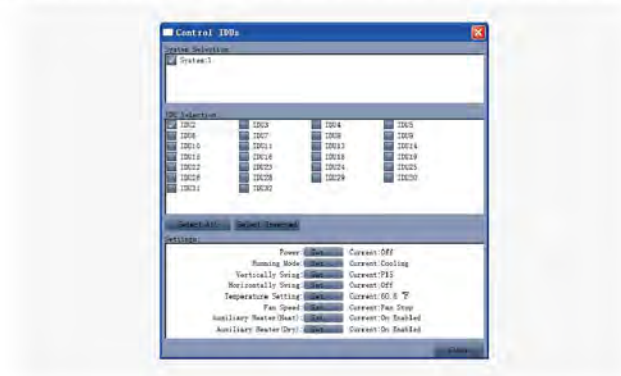

### Project Debugging Functions

- One-click and automatic project debugging;
- Project debugging is arranged step by step from left to right;
- Manual intervention and skipping of some debugging phases are available.
- Green icons will be displayed for the items finishing debugging; red icons will be displayed for the items having debug exception; light yellow icons display debugging information;



### Auto Data-Saving Function

Data will be saved automatically. Database saving path can be changed or data document can be generated repeatedly.

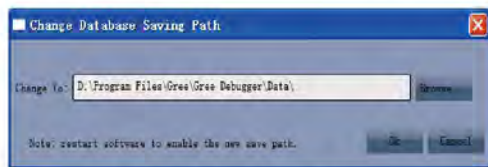

Step 1: Change Database Saving Path

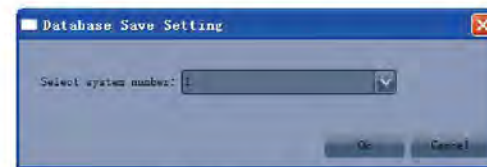

Step 2: Database Save Setting

### USB Data Converter

Users can use USB data converter to freely convert CAN/HBS/RS485 data into USB data, achieving data interchange between computer and air conditioner.

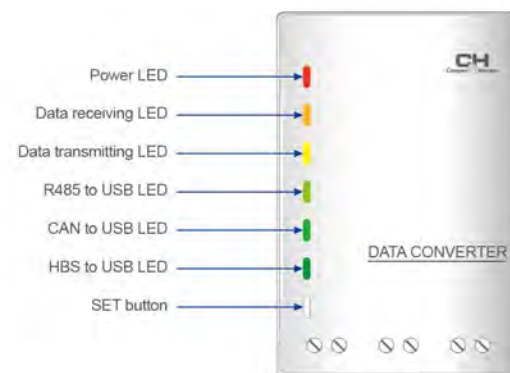

### Auto Direction of Connection Way

The wiring diagram will direct connection way automatically, so that the user can get the connection way quickly.

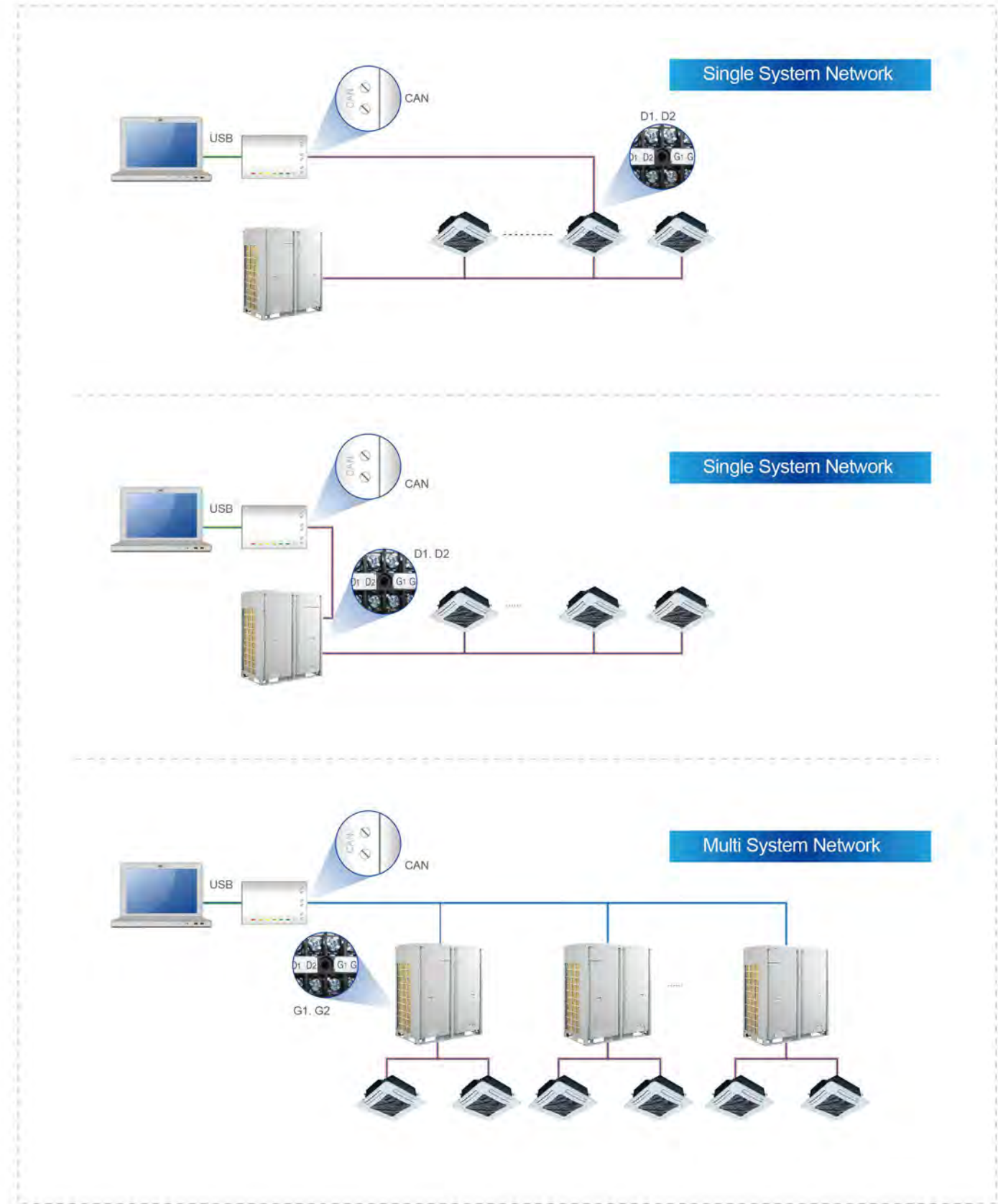

# Multiple Intelligent Remote Control Management

C&H CHV5 provides multiple intelligent controls in order to satisfy all demands. It can control both a room and a building at the same time.

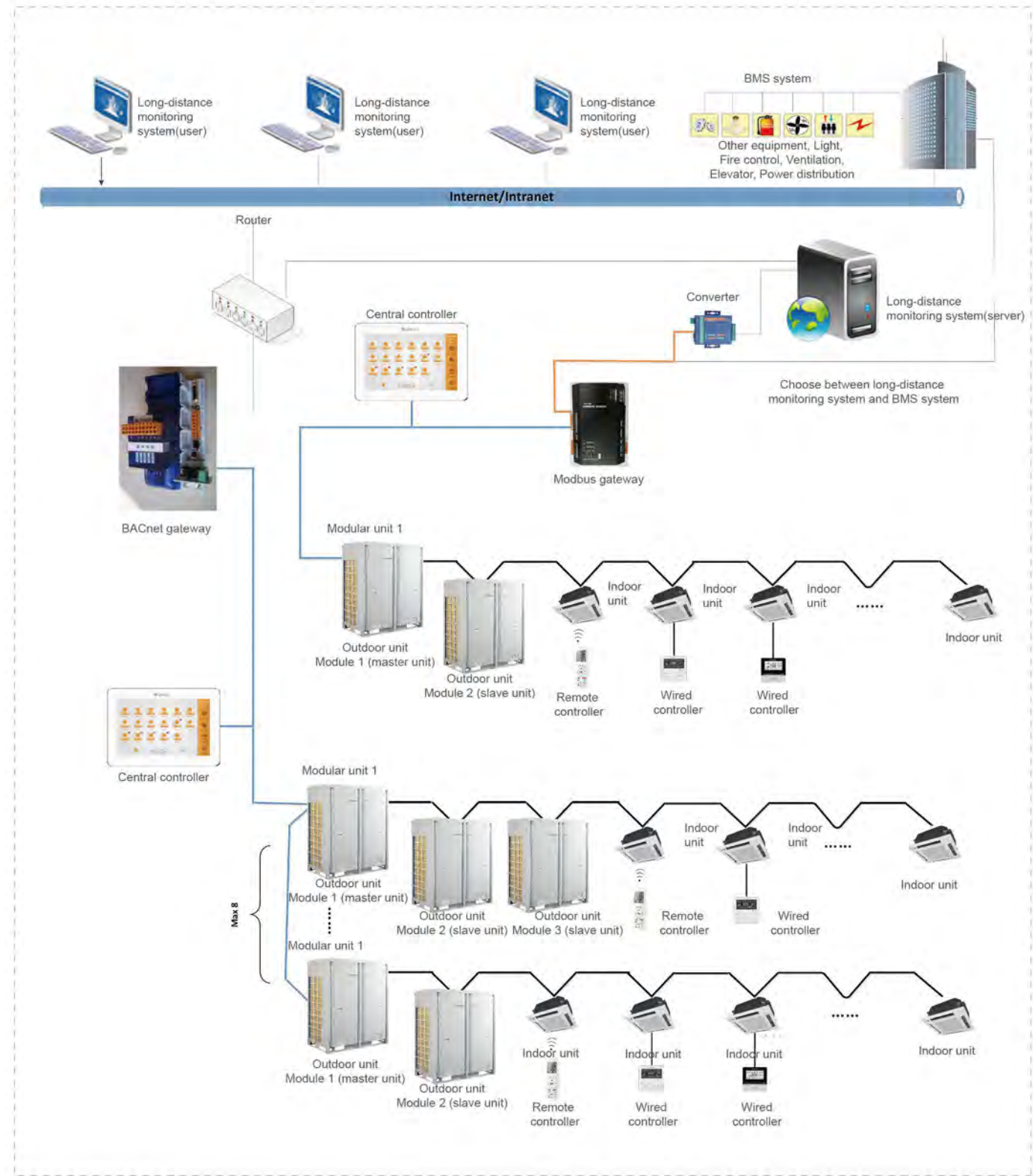

## Visualized Management

- System has a map that can display air conditioners' locations in rooms and buildings.
- System is able to measure the status and number of air conditioners in different levels



## Everyday Management

- **Setting for daily operation**
  - Management in days/weeks/months/years
  - Management in each unit
  - Simple display for management
- **Other functions**
  - Power on/off, modes, humidity, fan speed
  - Waste of energy that may be caused by forgetting to turn off the air conditioner can be avoided
- **Everyday Management at different locations**
  - Management for overtime working
  - Management for meal breaks
  - Management for working time

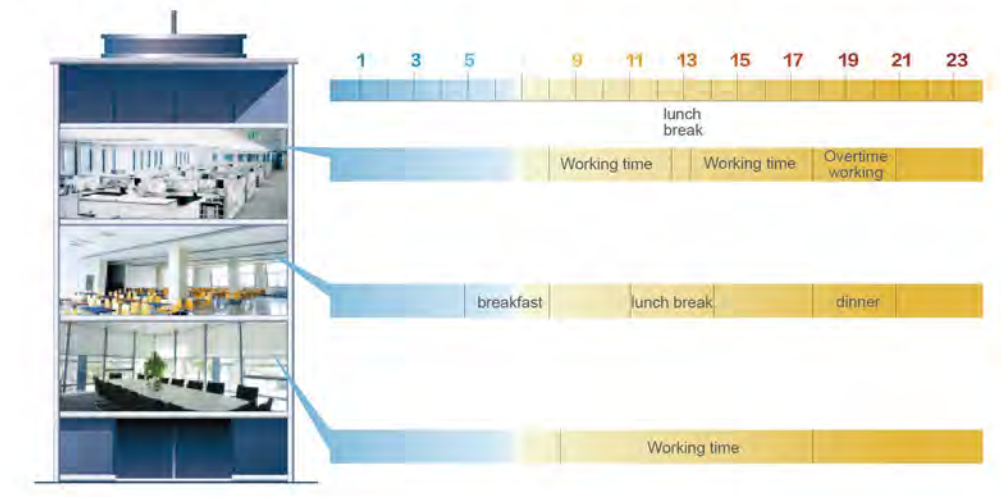

## Group Management

- **Central management in groups**
  - Free choices of dividing groups
  - Central control over power on/off
  - Central control over temperature
  - Central control over modes
  - Central control over user authority



## Authority Management

- **Only for indoor units**
  - Limited control over power on/off
  - Limited control over temperature
  - Limited control over modes



## Statistics Analysis

- **Recording statistics**  
System can self generate graphs of statistics for easy management and analysis.
- **Recording errors**  
System can show the information of errors in charts and send alarms of errors through emails.
- **Recording operation**  
System can record users' daily operation.

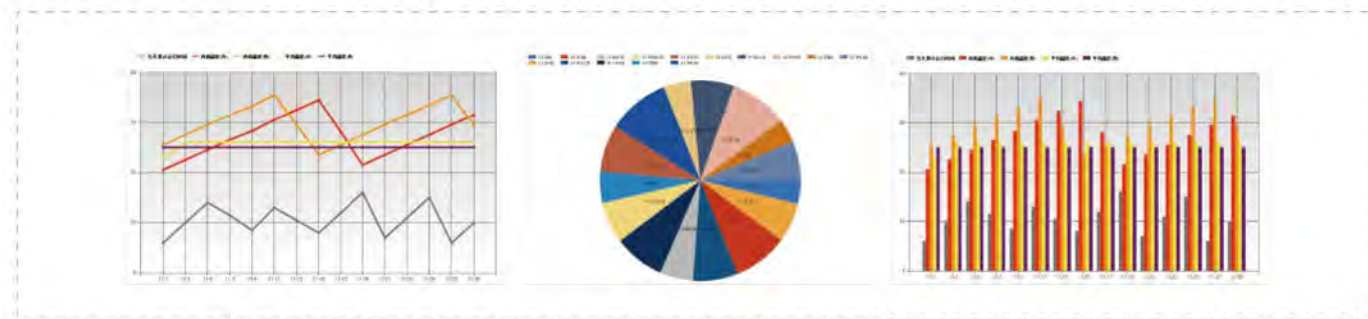

## Calculating Cost of Electricity

- Auto calculation according to users
- According to the operating time, modes, flow of refrigerant, humidity and other factors, system can calculate the cost of electricity for users in different locations.
  - Detailed information of bills and operation can be provided.



## Energy Management

- **Analysis of energy cost**
  - Air conditioners that cost much energy
  - Air conditioners that are set in low temperature
  - Air conditioners with bad cooling performance
- **Ways to save energy based on the following aspects:**
  - Operating time
  - Unit is on too early
  - Unit is off too late
  - Comfort
  - Cost of electricity/cost of electricity per square meter

## Energy saving

- **Limits on electricity**
  - Analysis on the cost of electricity
  - Set the maximum cost of electricity and unit will be operating in limited conditions when the maximum number is reached.
  - System can remind users the cost of electricity during operation and give suggestions on energy saving.
- **Economic operation**  
System is able to operate under an energy-saving condition



## VIP Management

System can provide independent and unique service to VIP users.



## Wired Controller and Remote Controller

There are two kinds of controllers: wired controller and remote controller. The system provides various controls for users, such as cooling, heating, dehumidifying and fan etc., users can select it flexibly according to their own using methods.

### Wired controller XK46



- LCD with black background and white words; touch buttons;
- Clock can be displayed and set; 24 hours timer setting for on/off;
- 7 levels of fan speed, up & down swing and left&right swing;
- Can be switched in auto, cooling, dehumidifying, fan, heating, floor heating, 3D heating and space heating operation modes;
- Master and slave wired controllers can be set; simultaneous control over several IDUs is available;
- Available functions: sleep, ventilation, quiet/auto quiet, light, energy saving, auxiliary heating, drying, memory, low-temperature dehumidifying, absence in heating, controllable auxiliary heating in dehumidifying, filter cleaning reminder, etc.;
- Detect ambient temperature; receive infrared remote controller signal;
- With project parameters viewing and setting functions.

### Wired controller XK49 (For hotel)



- With simplified functions, mechanical buttons, back lighting LCD and convenient operation;
- Can be switched in auto, cooling, dehumidifying, fan and heating operation modes;
- Master and slave wired controllers can be set; simultaneous control over several IDUs is available;
- Detect ambient temperature; receive infrared remote controller signal;
- With system parameters viewing and setting functions;
- 7 levels of fan speed, up&down swing;
- Door control system can be connected.

### Remote controller YAP1F



- Can be switched in auto, cooling, dehumidifying, fan and heating operation modes;
- Besides turbo, 6 levels of fan speed can be set;
- Available functions: child lock, drying, health, ventilation, turbo, sleep, light, absence, I-feel and timer;
- Clock display and indoor/outdoor ambient temperature viewing functions;
- Up & down swing and left & right swing.

### Remote Controller YV1L1



- Back lighting LCD;
- Can be switched in auto, cooling, dehumidifying, fan, heating, floor heating, 3D heating and space heating operation modes;
- 7 levels of fan speed, up&down swing and left&right swing;
- Available functions: child lock, energy saving, drying, health, ventilation, quiet/auto quiet, sleep, light, absence, low-temperature dehumidifying, I-feel and timer;
- With clock display, system parameters viewing and setting functions.

## Wired controller XK55



- Elegant appearance;
- High-resolution color LCD;
- Capacitive touch control; receive infrared remote controller signal;
- Various timing functions: three weekly timers and one countdown timer can be set simultaneously; mode, temperature and fan speed can be preset in weekly timer;
- Complete system functions; each function will be implemented in an individual page with interactive and humanized interface;
- Various personalized functions, e.g. setting brightness and backlight time;
- Sufficient viewing functions, e.g. viewing on/off status and after-sales service hot line.



- **Single control of one unit**

Each indoor unit has an independent controller.



- **Multiple control of one unit**

One indoor unit can be controlled by several wired controllers at different places.



- **Central control of several indoor units**

One wired controller can control as many as 16 indoor units.



- **Joint control of remote controller and wired controller**

Users can control one unit with two types of controllers: a remote controller which is convenient and flexible; or a wired controller which includes every function of an air conditioner.



## Smart Zone Controller and Central Controller

### Smart zone controller CE53-24/F(C)



- 1280\*800 high-resolution color LCD;
- 7" capacitive touch screen for easy operation;
- Shielding function of single unit, group and all IDUs (shielding on/off, mode, temp setting, etc.);

- With various functions: centralized control(control all indoor units), group management(support DIY grouping), schedule management(setting of several schedules) and single unit control(on/off, mode, temp setting, fan speed, quiet, swing control, etc.);
- Provide naming of indoor units, selection of icons and personalized settings(setting background, backlight, etc);
- Up to 32 units can be centrally controlled;
- Elegant and fashionable appearance;
- Embedded installation in wall with projecting thickness only of 11mm;
- Connectable with network of indoor units or outdoor units;
- Independent power supply in 110~240V wide voltage range;
- With project setting, parameter viewing, malfunction record and access management functions.

### Central controller CE52-24/F(C)



- 1280\*800 high-resolution color LCD;
- 7" capacitive touch screen for easy operation;
- With project setting, parameter viewing, malfunction record and access management functions.

- With various functions: centralized control(control all indoor units), group management(support DIY grouping), schedule management(setting of several schedules) and single unit control(on/off, mode, temp setting, fan speed, quiet, swing control, etc.);
- Shielding function of single unit, group and all IDUs (shielding on/off, mode, temp setting, etc.);
- Provide naming of indoor units, selection of icons and personalized settings(setting background, backlight, etc);
- Up to 128 units can be centrally controlled;
- Elegant and fashionable appearance;
- Embedded installation in wall with projecting thickness only of 11mm;
- Connectable with network of indoor units or outdoor units;
- Independent power supply in 110~240V wide voltage range;

## BACnet Gateway

BACnet gateway kits MG30-24/D2(B) are intended to realize the data exchange between the air conditioning unit and BAS, and providing the standard BACnet/IP building interface and 8 I/O interfaces, one of which is the fire alarm signal interface. The status of the other 7 I/O interfaces is mapped to the specific objects of the BACnet/IP bus and can be defined by the user.



Applicable models: CHV5 All DC Inverter Multi VRF System, CHV5 DC Inverter Multi VRF System, CHV DC Inverter Water Cooled Heat Pump Multi VRF System.

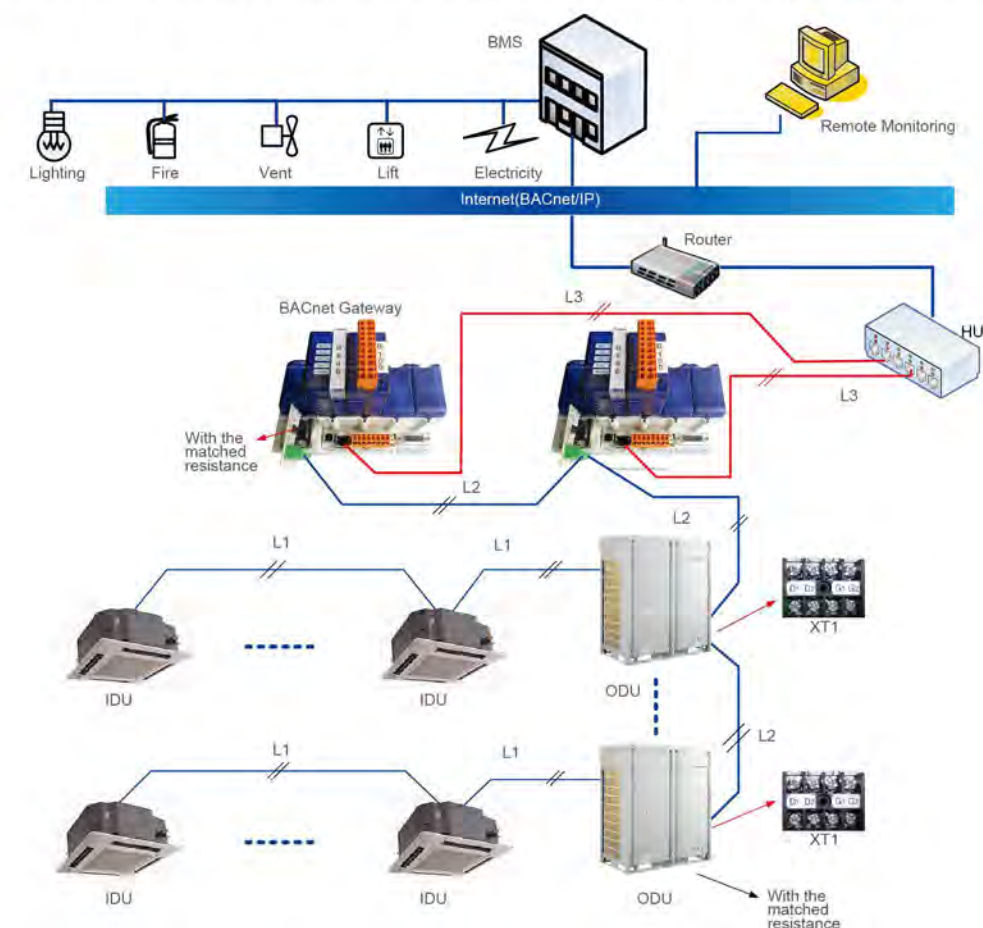

- International standard BACnet/IP interface, which has passed BTL certification;
- Real-time monitoring of unit operation status, e.g. on/off, mode, temperature;
- Real-time response to the control of unit (on/off, mode setting and speed setting, etc.) by monitoring software;
- Monitor unit errors;

- Lock unit operation statuses, directing at all control functions of unit itself or a certain setting function;
- Achieve cooling and heating temperature limitation functions;
- 8 DI/DO interfaces for receiving fire alarm signal and user's definition logic;
- Big storage capacity of unit operation data for 6 months.



# Modbus Gateway

Modbus Gateway provides CHV5 system with the Modbus protocol interface when connecting to the Building Management System(BMS) in order to achieve central control and remote control over CHV5 system by BMS.

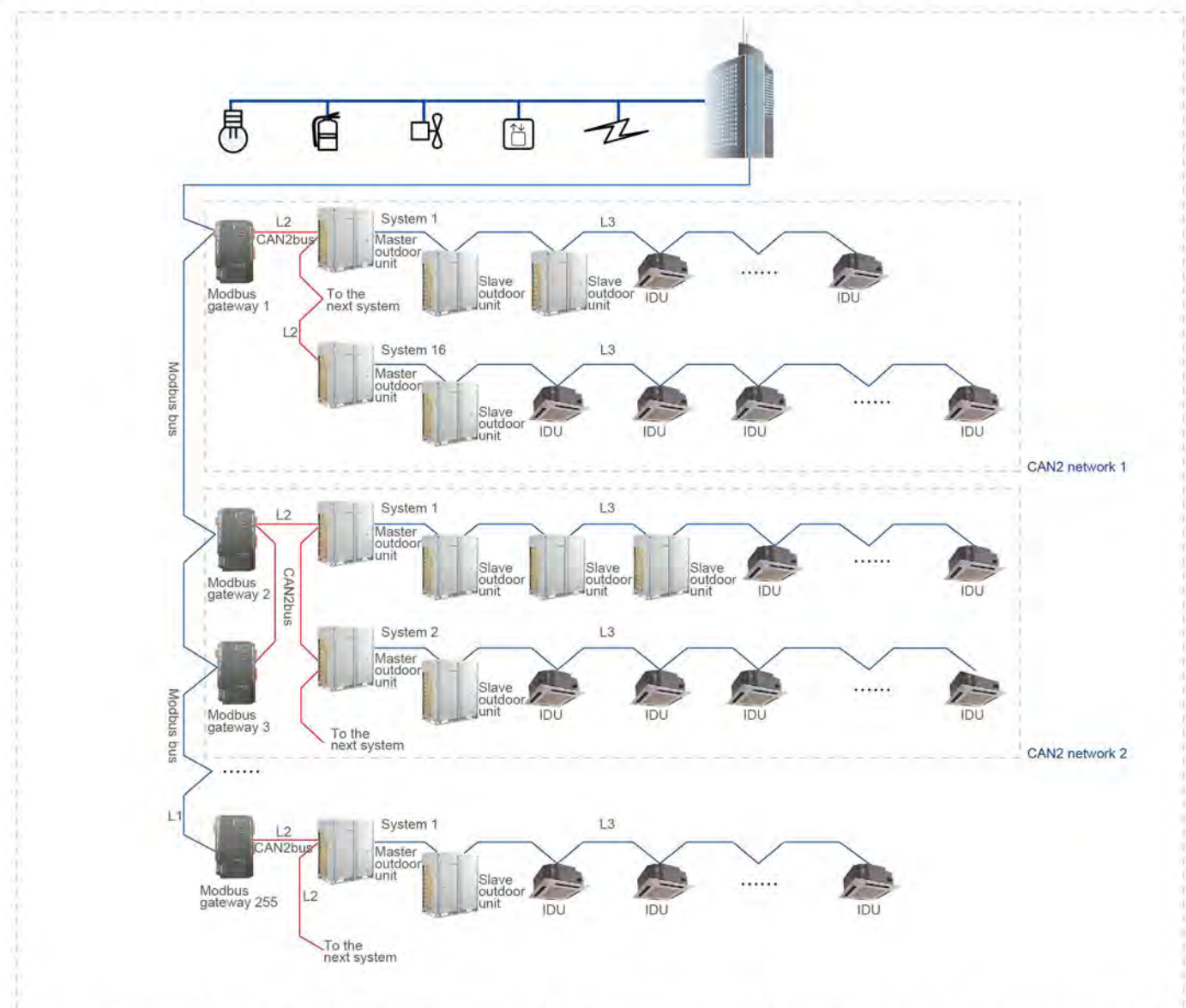

Applicable models: CHV5 All DC Inverter Multi VRF System, CHV5 DC Inverter Multi VRF System, CHV DC Inverter Water Cooled Heat Pump Multi VRF System.

- Real-time monitoring of unit operation status, e.g. on/off, mode, temperature;
- Real-time response to the control of unit (on/off, mode setting and speed setting, etc.) by monitoring software;
- Control all the units switches of on and off.
- Monitor unit errors;
- One Modbus bus can support up to 255 gateways. One Modbus gateway can support at most 16 outdoor units(up to 64 modular outdoor units) and 128 indoor units;
- Lock unit operation statuses, directing at all control functions of unit itself or a certain setting function;
- Linkage control, supporting 5 DI and 5 DO for receiving fire alarm signal and user's definition logic;
- CAN, RS485 communication ports are non-polar, convenient for construction wiring;
- Achieve cooling and heating temperature limitation functions;
- 100-240 VAC,50/60Hz wide voltage range, adapted to the power supply of each country and region.

# Control System Lineup

Controlling system		Product series	Cassette Type	(High ESP, Low ESP, Slim Ducted) Duct Type	Fresh Air Processing	Wall mounted Type	Floor Ceiling Type	Console Type	Floor Standing Type	Air Handler
Wireless Controller	YAP1F		●	○	○	●	●	●	●	○
	YV1L1		○	○	○	○	○	○	○	○
Wired controller	XK46		○	●	●	○	○	○	○	●
	XK49		○	○	○	○	○	○	○	○
	XK55		○	○	○	○	○	○	○	○
	JS05(receiver)			○	○					
Centralized Controller	CE52-24/F(C)		○	○	○	○	○	○	○	○
Smart Zone Controller	CE53-24/F(C)		○	○	○	○	○	○	○	○
Long-distance monitoring software	FE31-00/AD(BM)		○	○	○	○	○	○	○	○
BMS Accessories	Communication module(modbus)	ME30-24/E4(M)		○	○	○	○	○	○	○
	GMV BACnet gateway (BACnet)	MG30-24/D2(B)		○	○	○	○	○	○	○
Other modules	Optoelectronic isolated converter	RS232-RS422/485		○	○	○	○	○	○	○
	Optoelectronic isolated signal multiplier	RS-422/485		○	○	○	○	○	○	○

Note: ● means standard, ○ means optional.

# Energy Recovery Ventilation(ERV)



- Air flow: 350~3000m<sup>3</sup>/h
  - Energy Recovery Ventilation System can introduce the fresh air freely on the condition that all the windows closed or exhausted fan uninstalled. It can solve the problem of stagnant air effectively.
- It is usually installed in the ceiling of corridor and supplies fresh air to each room through ducts.

## Adopt Advanced Heat Exchange Core

ERV adopts cross flow plate exchanger with air volume below 3000m<sup>3</sup>/h. Fresh air will be introduced and internal leakage is low, which effectively prevent pollution to fresh air.

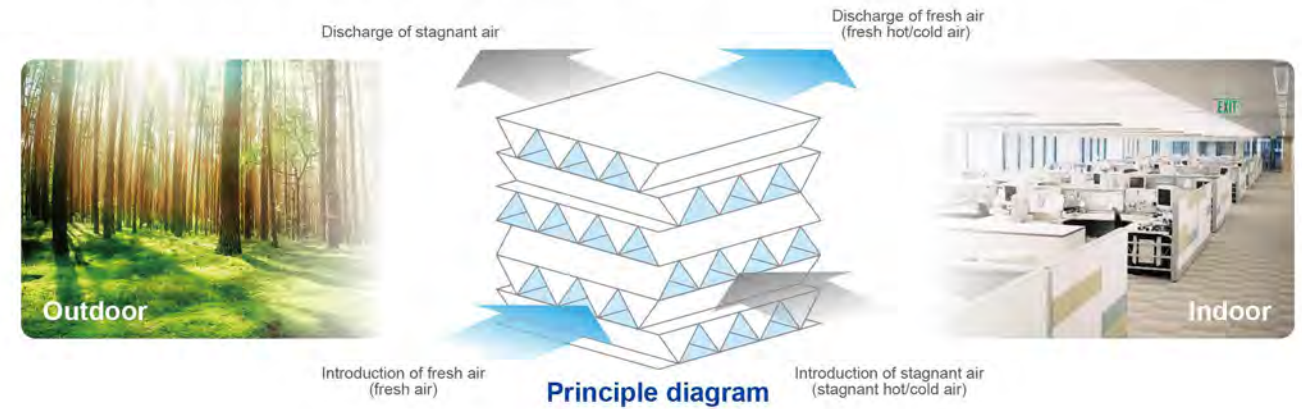

## Double-way Ventilation for Fresh Air

ERV can not only introduce lots of fresh air, but also discharge the stagnant air at the same time, which effectively minimizes the toxic air from the inner and other materials. The ventilation effect is very obvious, ensuring enough supply of fresh air to the indoor space.

## No Cross Contamination for Ensuring Healthy Fresh Air

The unique cross-flow heat exchange valve sub-assy is adopted. There is only energy exchange between indoor air and outdoor air with little exchange of air, which effectively prevents cross contamination and "air-condition" disease.



## Pretreatment of Fresh Air for Energy-saving

When fresh air is introduced, its temperature and humidity will be exchanged with the discharged warm air. As the fresh air is preheated and humidified, energy is saved and load of unit is reduced.

## Energy Recovery Ventilation(ERV)

Model			FHBQ-D3.5-K	FHBQ-D5-K	FHBQ-D8-K	FHBQ-D10-K	FHBQ-D15-M	FHBQ-D20-M	FHBQ-D30-M	FHBQ-D5-D	FHBQ-D8-D*	FHBQ-D10-D	FHBQ-D15-D*
Air flow volume	H/M/L	M3/h	350	500	800	1000	1500	2000	3000	500	800	1000	1500
ESP	H/M/L	Pa	100	100	110	110	150	150	220	100	100	110	150
Temperature exchange efficiency	H/M/L	%	71.00	68.00	70.00	73.00	73.00	71.00	70.00	68.00	70.00	75.00	73.00
Enthalpy exchange efficiency(H/M/L)	Heating	%	65.00	62.00	63.00	66.00	65.00	62.00	62.00	62.00	63.00	66.00	65.00
	Cooling	%	61.00	57.00	60.00	62.00	60.00	58.00	58.00	57.00	60.00	62.00	60.00
Power supply	Ph/V/Hz		1/220/50	1/220/50	1/220/50	1/220/50	3/380/50	3/380/50	3/380/50	1/220/60	1/220/60	1/220/60	3/220/60
Power input	KW		0.185	0.262	0.40	0.44	0.80	0.95	2.80	0.262	0.50	0.50	1.10
Sound Pressure Level	Db(A)		37	39	45	46	48	50	54	39	50	46	60
Dimension (W*D*H)	Outline	mm	800*879*306	800*879*306	832*1016*380	832*1016*380	1210*1215*452	1210*1215*452	1340*1550*572	800*879*306	832*1016*380	832*1016*380	1210*1215*452
	Package	mm	1050*1165*315	1050*1165*315	1087*1320*400	1087*1320*400	1540*1550*470	1540*1550*470	1610*1710*700	1050*1165*315	1087*1320*400	1087*1320*400	1540*1550*470
Net weight	kg		45	45.0	57.0	57.0	110.0	110.0	215.0	45.0	57.0	57.0	110.0
Gross weight	kg		53	53.0	66.5	66.5	130.0	130.0	236.0	53.0	66.5	66.5	130.0
Loading quantity	40'GP	set	147	147	85	59	37	37	24	147	59	59	37
	40'HQ	set	168	168	104	67	44	44	24	168	67	67	44
Standard wired remote controller			Z5N151	Z5N151	Z5N151	Z5N151	Z5N151	Z5N151	/	Z5N151	Z5N151	Z5N151	Z5N151

Note  
\*1: This product only gets CB certification.

## Control System Lineup

Product series			ERV
Control system			
Wired controller	Z5N151		●
Interface of the main board	BMS		●
Optoelectronic isolated converter	RS232-RS422/485		○
Optoelectronic isolated signal multiplier	RS-422/485		○

Note: ● means standard, ○ means optional.

## Note

# Award and Certification

